

DIAMOND DUST RC

Diamond Dust CW Kit

ASSEMBLY MANUAL

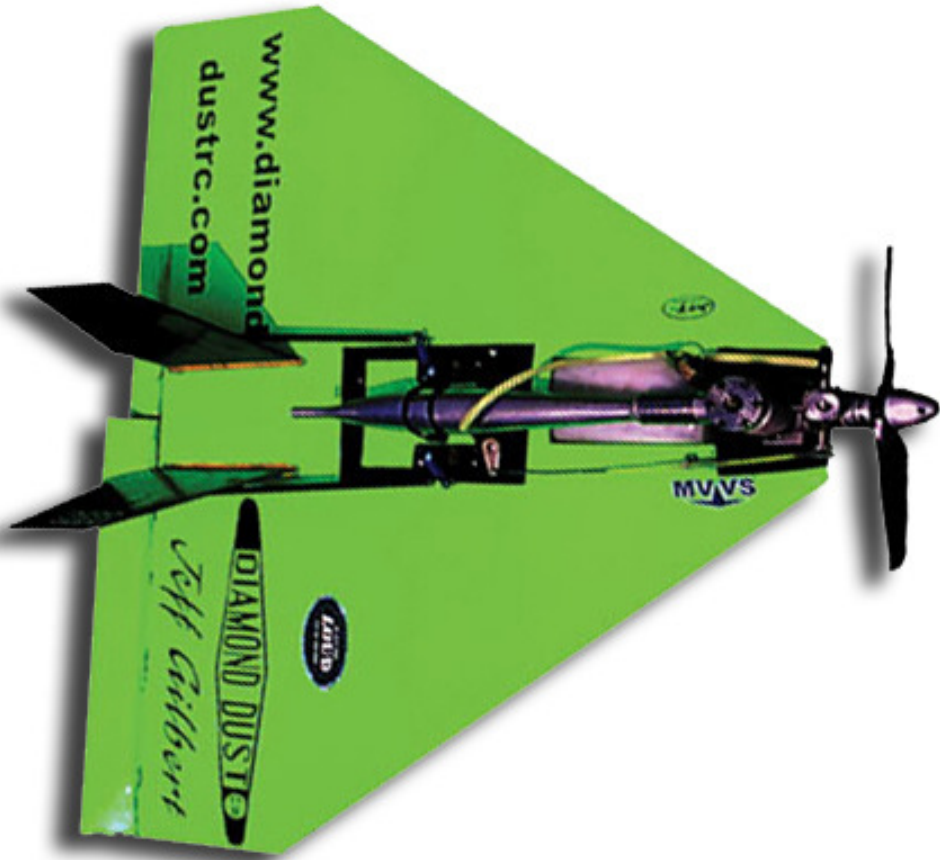

Specifications

Wingspan: 29.75 in (755.65mm)
Length: 24.50 in (622.30mm)
Wing Area: 468 sq in (30.19 sq dm)
Weight: 2.25 – 3.0lbs (1020g–1360g)

Engine size:25 - .40 2 cycle
Wing Loading 12oz/SF
Radio: 4-channel w/3 servos

Table of Contents

Introduction	3
Warranty Information	4
Contents of Kit	5
Required Radio and Engine.	6
Additional Required Tools and Adhesives.	7
Section 1: Framing of the Airframe	8
Section 2: Elevon Construction	33
Section 3: Vertical Fin Assembly	37
Section 4: Installing the Control Horns and Elevon Linkage.	40
Section 5: Equipment Placement and Pre-Balancing.	44
Section 6: Covering the Aircraft.	45
Section 7: Fuel Tank Installation	50
Section 8: Final Equipment Installation.	51
Section 9: Final Inspection / Control Throws.	54
Section 10: Balancing the Diamond Dust.	55
Section 11: Pre-Flight & At the Flying Field	56

Introduction

Thank you for purchasing the Diamond Dust Clipped Wing Kit high performance delta wing aircraft. Backed by Diamond Dust's high quality reputation, the Diamond Dust CW will provide you with the superior performance and features you are looking for in a high speed high performance aircraft. The Diamond Dust CW features lightweight balsa, composite tubes, and light-ply construction. This lightly loaded delta wing design makes it ideal for extremely aggressive maneuvers as well as excellent low speed maneuverability.

Before Starting Assembly

Before beginning the assembly of your Diamond Dust CW, remove each part from the box and the parts bag for inspection. Closely inspect the wood pieces and parts bag for damage. If you find any damaged or missing parts, contact the place of purchase.

Using the Manual

This manual is divided into sections to help make assembly easier to understand and to provide breaks between each major section. Remember to take your time, and follow the directions closely. You can also check on the Diamond Dust RC website for any updates to this manual at www.diamonddustrc.com.

Also there are a number of steps in the assembly of the Diamond Dust and Diamond Dust Clipped Wing version that are identical. For practicality and efficiency reasons, some pictures in this manual may show the Stock Diamond Dust in the illustrations. This should not be a problem since the majority of the steps are identical for both aircraft. If you have any questions, please don't hesitate to contact our tech support line at (352-871-7301) Monday through Friday, between the hours of 8am to 6pm EST.

Warranty Information

Tetracam, Inc. and Diamond Dust RC, guarantees this kit to be free from defects in both material and workmanship at the date of purchase. This warranty does not cover any component parts damaged by use or modification. In no case shall the liability to Tetracam, Inc. exceed the original cost of the purchased kit. Further, Tetracam, Inc. reserves the right to change or modify this warranty without notice.

In that Tetracam, Inc. and Diamond Dust RC have no control over the final assembly or materials used for the final assembly, no liability shall be assumed nor accepted for any damage resulting from the use of the final assembled product. By the act of using the assembled product, the user accepts all resulting liability. Please note that once assembly of the model has been started, you must contact Tetracam, Inc. directly regarding any warranty questions. Please do not contact your local hobby shop regarding warranty issues, even if that is where you purchased it. This will enable Tetracam, Inc. to better answer your questions and service you in the event that you may need any assistance. If the buyer is not prepared to accept the liability associated with the use of this product, the buyer is advised to return this kit immediately in new and unused condition to the place of purchase.

Warning

An RC aircraft is not a toy! If misused, it can cause serious bodily harm and damage to property. Fly only in open areas, preferably at AMA (Academy of Model Aeronautics) approved flying sites, following all instructions included with your radio and equipment.



Tetracam, Inc
Devonshire St.
Suite 310
Chatsworth, CA 91311
Sales - (818) 718 -2119
Tech Support – (352) 871-7301
www.tetracam.com

Contents of Kit – Diamond Dust CW

Main Box

Qty	Description
1	Assembly manual
1	Blueprint / Plan
2	14 1/4" Main wing spars (Front & Rear)
2	Rear main spar extenders Tubes (.300" x 6-3/4")
2	Approximately 23" Leading Edge tubes (.300" O.D.)
2	Root ribs (#1 Ribs)
2	Mid wing ribs (#2 Ribs)
2	Tip ribs (#3 Ribs)
1	1/16" Balsa partial rib
1	1/8" Plywood engine mount
1	1/8" Plywood engine mount doubler
1	1/8" x 3-7/8" x 1-3/4" Plywood switch plate
2	Balsa Wing tips (Precut 1/4"x1-1/2" elevon stock)
2	Elevon stock (1 1/2" x 3/8")
6	1/2" x 1/16" x 36" Balsa cap strips
8	4" x 4-5/8" x 1/16" Balsa sheets
1	4/ x 4-5/8" x 1/16" Balsa sheet with precut slots.
2	1/8" precut vertical fin (front half)
2	1/8" precut vertical fin (rear half)
1	1/4" x 3/8" Balsa trailing edge stock
3	1/4" x 1/4" x 36" Balsa triangle stock
1	1/16" x 1-3/4" x 4" Balsa fuel tank compartment rear bulkhead
1	3/16" Antenna tube 36"
1	1/32" antenna pull tube 36"
1	Diamond Dust CW decal
2	4-40 Pushrods
1	2-56 Pushrod
2	Composite pushrod stiffener tubes

Qty	Description
2	1/8" x 1/8" Bass wood coving stock (For Leading Edge)
1	6oz Fuel tank with hardware
2	.005" Carbon fiber Strip (1/4"x34")

Hardware Bag

Qty	Description
1	1/8" x 3/4" x 3-7/8" Plywood firewall
2	1/4" x 1/4" x 4-3/8" Hardwood servo rails
2	1/4" x 1/4" x 7/8" Hardwood servo rails
4	1/8" x 1/8" x 4" balsa fin offset spacer/ Fin cap strip.
4	1/8" x 1/4" x 1/2" Plywood spar end / rib locking tabs
4	1/8"thick 1 1/4" x 1 1/4" Triangle gusset
1	Spool Kevlar thread
10	CA Hinges
11	#19 Rubber bands
2	HD Control horns with base plate
2	4-40 Ball links
2	#4 Ball Link bushing
1	2-56 Nylon clevis
1	1" wide x 15' roll of Solartex
8	4-40 x 1" Socket head cap screw
2	4-40 x 5/8" Socket head cap screw
2	4-40 Nylon insert locknut
1	Velcro strip

Required Radio and Engine

Radio Equipment

- 4-channel radio system (minimum)
- 2 High torque digital servos (JR9411 recommended or equivalent)
- 1 HS 85MG or equivalent mini servo

Engine / Power System

Any .25 to .40 two stroke RC engine

(Recommended Items)

SERVOS

Throttle:

JR: 331Micro or 3121 Mini

Hitec: HS-85MG Mini servo

Elevon .28 and under:

JR: DS537

Hitec: HS475

Elevon .30and above:

JR: DS9411 or DS8611A

Hitec: HS-7985MG

NOTE: Since there are so many servo choices available, please compare and match as closely as possible, the specifications of the above mentioned servos with the servos you intend to use

Additional Required Tools and Adhesives

Tools

- Drill
- Drill bits: 1/16", 3/32", 7/64", 1/8"
- Hobby Knife
- Razor saw or hacksaw
- #2 Phillips Screwdriver
- 120 or 240 grit sandpaper
- Sanding Block or Permagrit File
- Scissors
- 3/32" hex driver or Allen wrench
- Pliers
- Ruler or measuring tape
- Speed square or small square
- Soldering Iron
- Heat Gun
- Covering Iron
- Pencil

Adhesives

- Thin CA Glue (Cyanoacrylate)
- Thick CA Glue (Cyanoacrylate)
- CA Accelerator
- CA Remover / Debonder
- Stix-It Covering Adhesive

Other Required Items

- Wax paper or Parchment paper
- Foam pad or rubber pad for fuel tank
- Epoxy Brushes

Section 1: Framing of the Airframe

Step 1

Locate all parts listed in materials list, and take inventory of all parts. This will help you familiarize yourself with the various components.

Lay your print out on large flat surface (*the larger and flatter the better*). Cover your plans with either parchment paper or wax paper and tape them down to secure to your work surface.

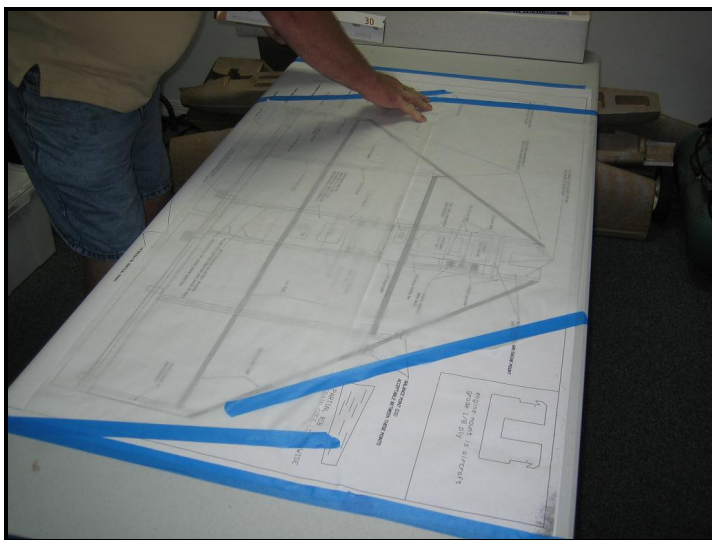

Step 2

Assemble the rear spar by locating the tubes labeled “Rear Spar” and “Spar extenders”. Insert the spar extenders into each end of the rear spar. You may have to lightly sand the spar extenders so that they go into the rear spar with a moderate amount of force, but first try the opposite end of the spar extender tube to see which end fits the best.

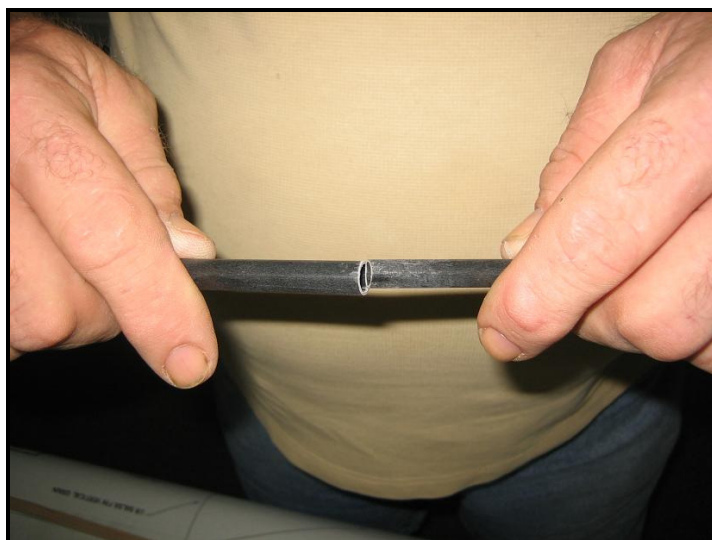

Section 1: Framing of the Airframe – Cont.

□ Step 3

Lay the assembled spar on the print to see how far the tubes should fit into one another. Adjust both sides so the center main spar is centered on the print and the end tubes extend to the correct length shown on the print (*be as precise as possible when matching the print through all the steps*).

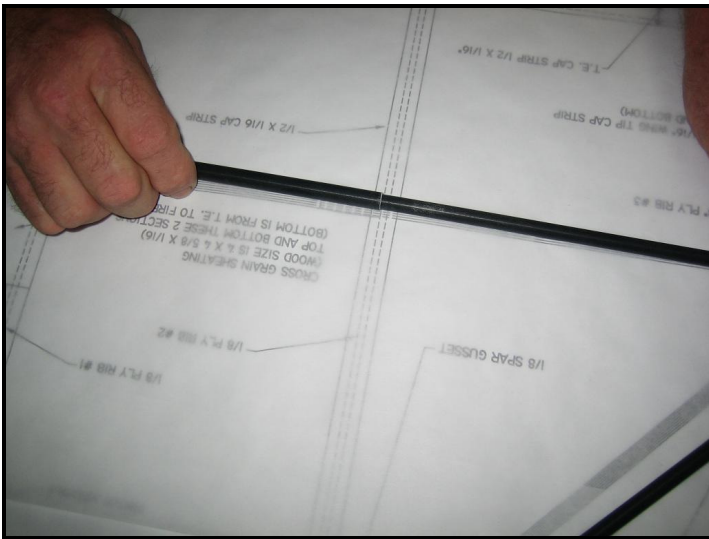

When the rear spar matches the print (tube engagement and overall length), apply a drop of thin C.A. on each joint.

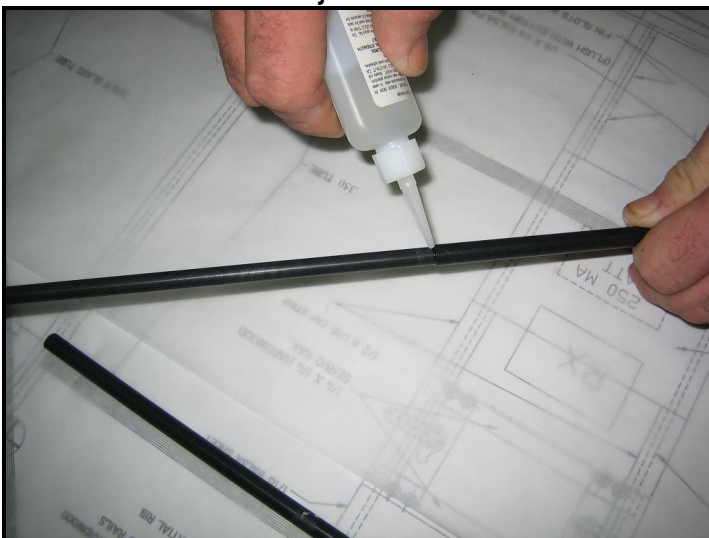

□ Step 4

Find the $\frac{1}{4}$ " x $\frac{3}{8}$ " x 36" balsa stick trailing edge (T.E) and cut it the same length as shown on the plan.

Find one of the $\frac{1}{4}$ " x $\frac{1}{4}$ " x 36" triangle stock, and also cut it to match the trailing edge you just cut. Center the triangle stock on the $\frac{1}{4}$ " side of the $\frac{1}{4}$ " x $\frac{3}{8}$ " T.E. Glue the triangle stock to the $\frac{1}{4}$ " side with thick CA.

Next, find two $\frac{1}{16}$ " x $\frac{1}{2}$ " cap strips that seem to be the stiffest from the wood supplied with the kit. Cut them to match the length shown on the plans.

NOTE: Do not glue the T.E. cap strips beyond the #2 ribs until the wing tips are installed in step #16.

Examine the drawing below to ensure proper assembly of the T.E assembly.

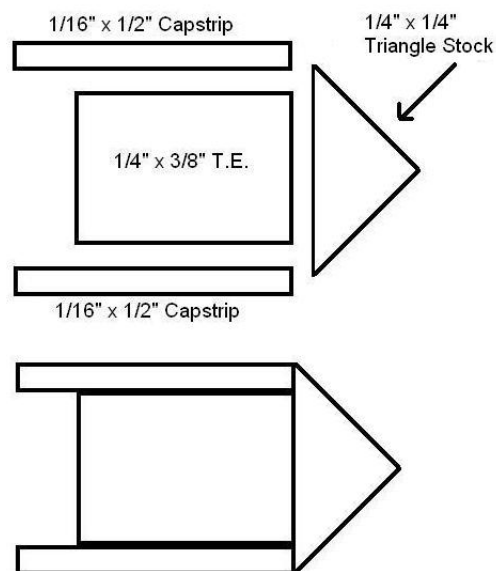

When you are done assembling the T.E., set it aside until step 10.

Section 1: Framing of the Airframe – Cont.

□ Step 5

Take the two center ribs (*rib #1*) and locate the square 1/4 x 1/4 servo rail holes. **Note: the square holes are closest to the top side of the airfoil.**

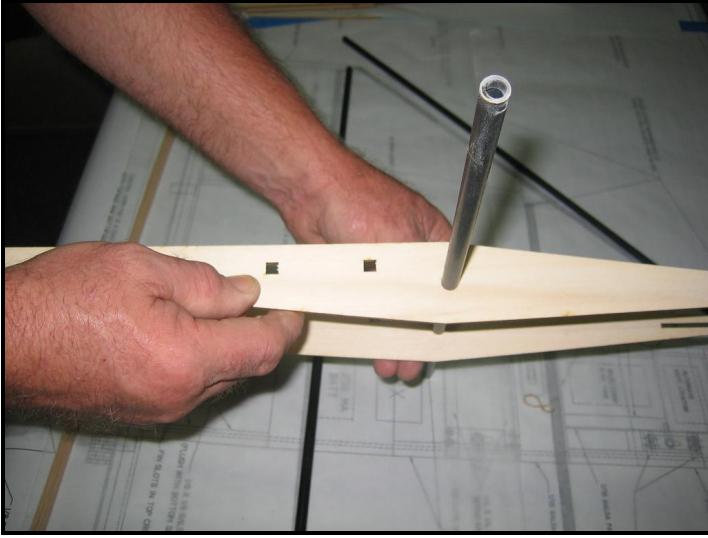

Next, hand slide the front and rear spars onto the center ribs (*#1 ribs*). Align the ribs and position them as shown on the print. **Do not glue anything yet!!!**

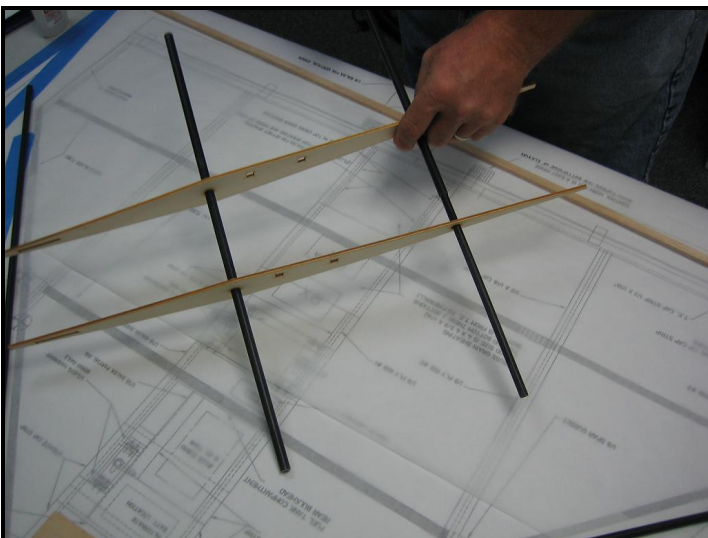

□ Step 6

Install one #19 rubber band (*included*) over each rear spar half and one rubber band over each forward spar half, as shown below. Note: you will need to double turn the rubber bands that go over the forward spar halves.

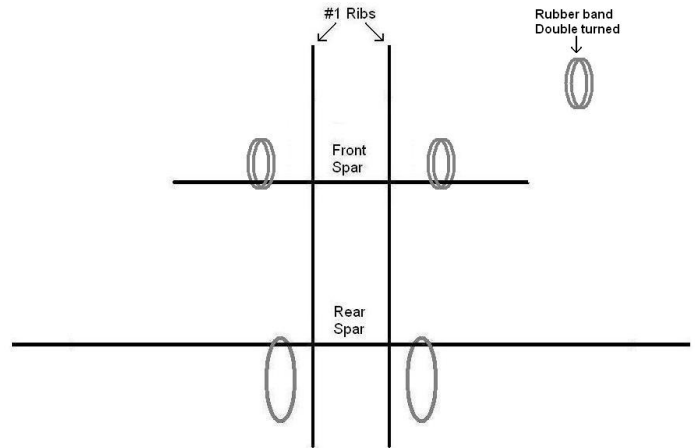

Next, slide the #2 ribs over the rear spar. Add one more rubber band to each side of the rear spar and one diagonally around the rear spar and rib #2, as shown below.

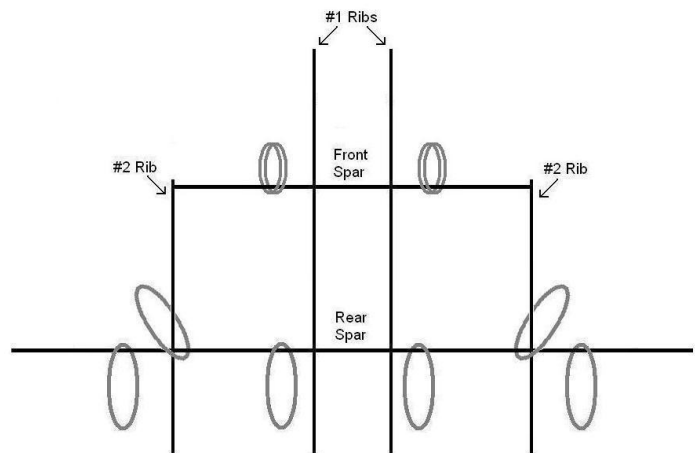

Section 1: Framing of the Airframe – Cont.

□ Step 7

Place the engine mount in between the two #1 ribs. You will first have to insert the front part of the #1 ribs into the front part of the mount in order to clear the leading edge locking tabs.

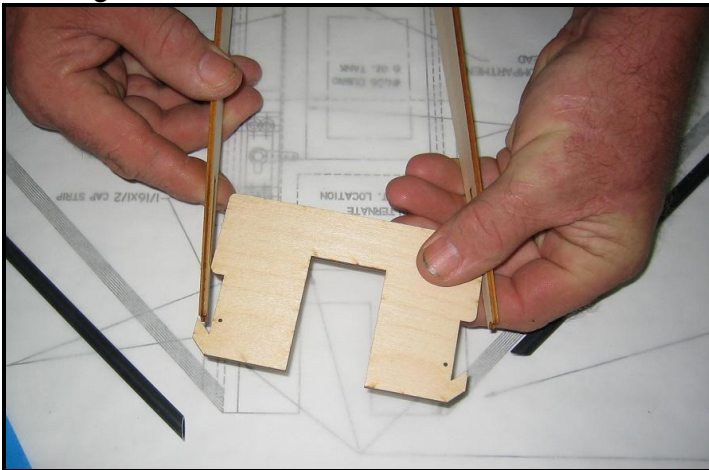

Next, temporarily secure the mount into position by using one #19 rubber band around it and the #1 ribs. You will have to double the turns on the rubber band in order to achieve a strong hold

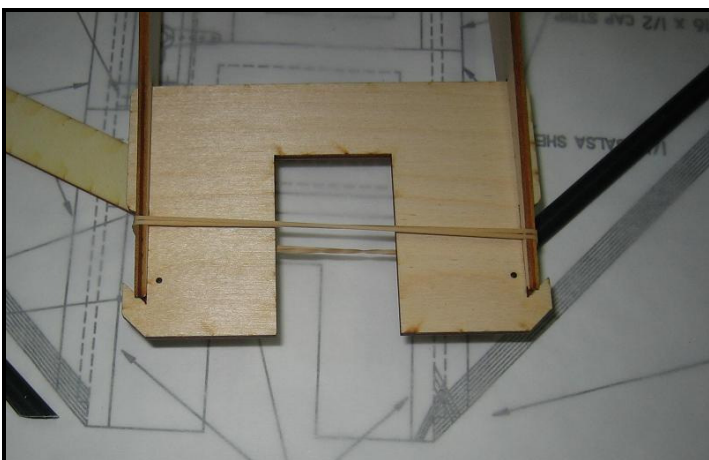

□ Step 8

Take the 1/16" x 1-3/4" x 4" balsa fuel tank compartment rear bulkhead and lay it vertically against the front of the front spar between the #1 ribs. Place a #19 rubber band around the ribs to secure the bulkhead as a spacer. You may have to double the turns on the rubber band in order to achieve a strong hold. **Do not glue yet!!!**

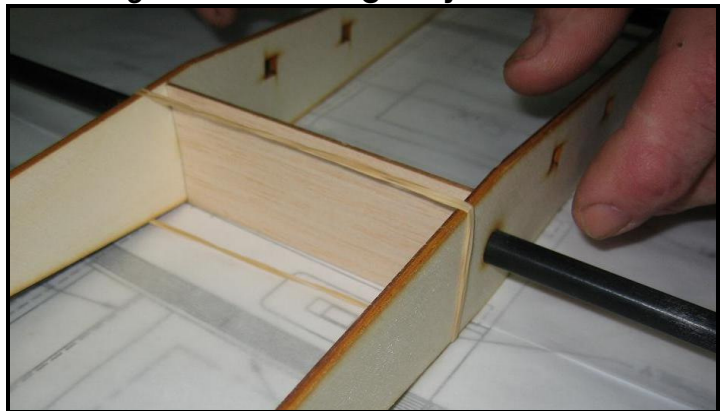

Next take the 1/8" x 3-7/8" x 1-3/4" plywood switch plate and place it vertically on the rear spar between the #1 ribs. Place a large rubber band around the ribs to secure the switch plate as a **temporary** spacer.

NOTE: Do not glue this plate to the ribs or rear spar !!!

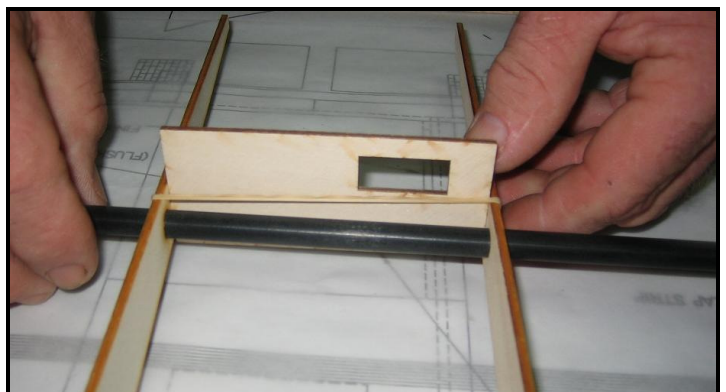

Section 1: Framing of the Airframe – Cont.

□ Step 9

Center the forward spar with the alignment hole in the #2 rib (*centered top and bottom*), and insert one of the 1/8" x 1/4" x 1/2" plywood spar end / rib locking tabs through the rib and into the spar. Put a few drops of thin CA where it is connected. Repeat on the opposite side.

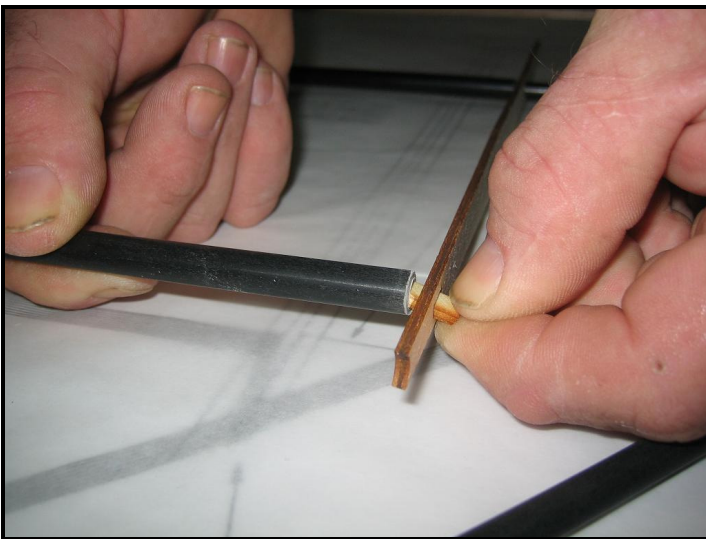

□ Step 10

Take the trailing edge assembly from step 4 of this section and slide it through the four #19 rubber bands that are on the rear spar. Place the rubber bands so they are alongside the #1 ribs and on both sides of the #2 ribs, as shown below. Line up all spars and ribs to match the print as precisely as possible.

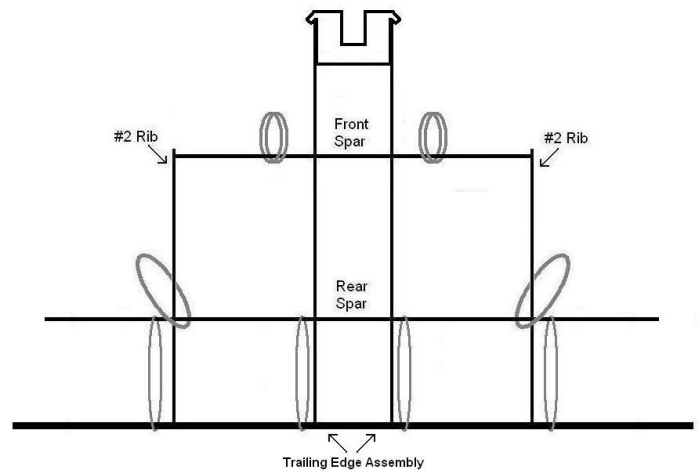

When in place, put a drop of thin CA at each rib to tack in place.

Note: the trailing edge of the ribs should self center in between the 1/16" cap strips on the T.E. assembly.

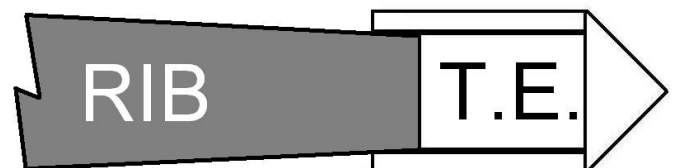

Section 1: Framing of the Airframe – Cont.

□ Step 11

Square up and center the #3 rib on the T.E and the rear spar extender. Next, insert the wood tab through the #3 rib into the rear spar extender. When everything is aligned and square, first glue with thin CA and then with thick CA. Repeat this step for the opposite side.



Make sure that everything lines up on the print and finish gluing all ribs to the trailing edge.

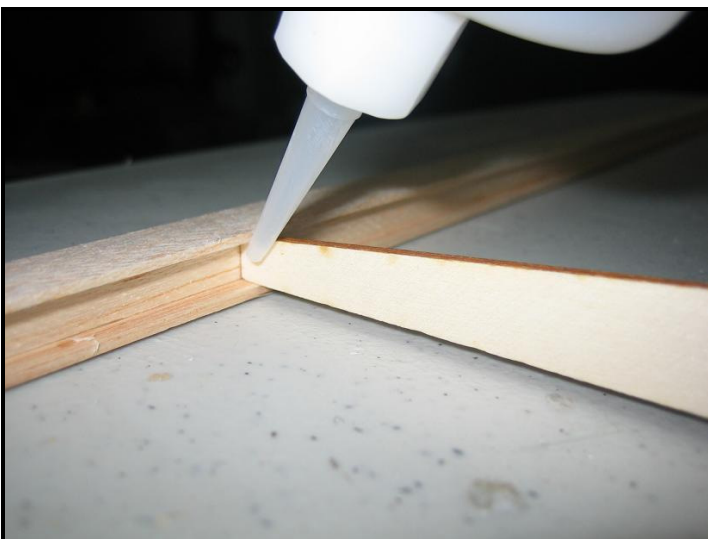

□ Step 12

NOTE: be careful not to glue the temporary spacers at the spars or the rubber bands.

Make sure the fuel tank compartment rear bulkhead is square and then first glue with thin CA then with thick CA.

Next, glue the main ribs to both the forward and rear spars first using thin CA, then fill in around the spars with thick CA.

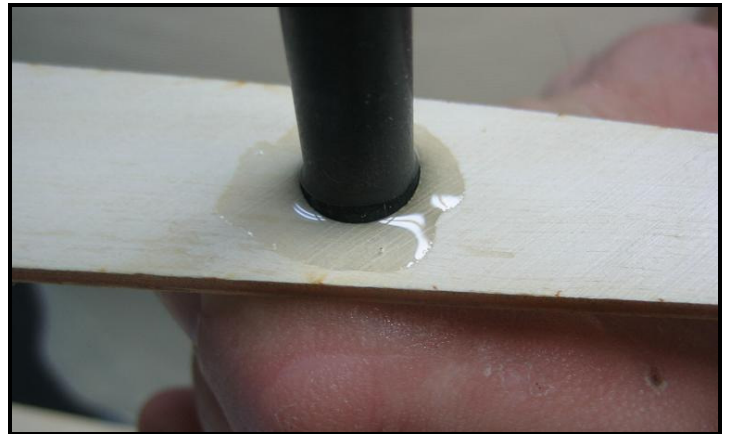

You can now cut the four rubber bands that hold the T.E. assembly. Keep the remaining rubber bands on the airframe, since you will need these to install the leading edges of the aircraft.

Section 1: Framing of the Airframe – Cont.

□ Step 13

Next you will be installing the leading edges on the airframe. Find the two tubes labeled “L.E. Tubes” and slide each one through the double rubber bands attached to the forward spar halves. Make sure the 45 degree cuts are facing the motor mount.

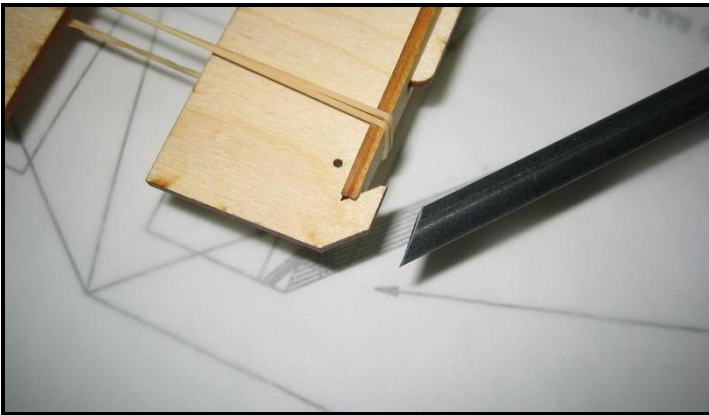

Insert the L.E. tube into the angled motor mount tabs and rest the tube on both the #2 and #3 ribs.

Note you may have to slide the rubber band back in order to increase the tension between the L.E. and the front spar.

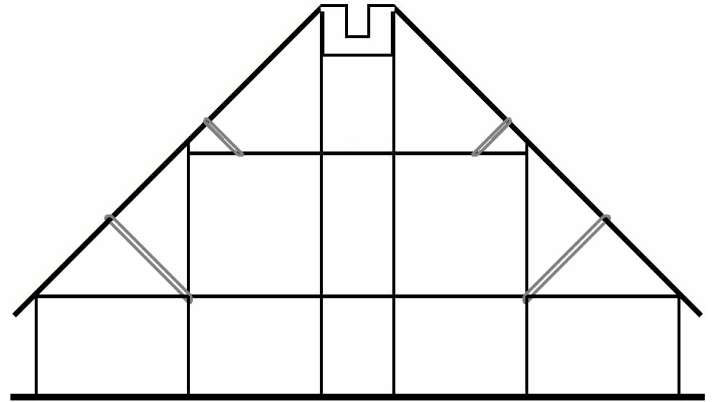

Once you have both leading edges aligned and sitting on both the #2 and #3 ribs, place a drop of thick CA on both sides of the #2 and #3 ribs at the leading edge. *The square end of the L.E. tube will extend beyond the wing tips. Leave this extra length for now.*

□ Step 14

Next, Locate the 1/8" x 3/4" x 3-7/8" plywood firewall and center it between the #1 ribs and the motor mount plate. Apply glue on both sides, where the firewall intersects the #1 ribs and where it touches the motor mount, with both thin and then thick CA. Then, cut the rubber bands holding the motor mount.

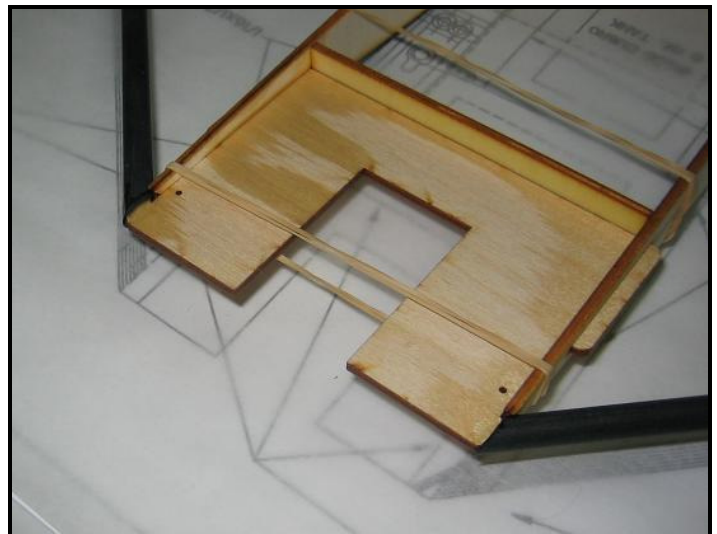

Section 1: Framing of the Airframe – Cont.

□ Step 15

Locate the triangle gussets from the parts bag. The first ones are installed behind the leading edge at the motor mount. Glue them in with thick CA in the location shown on the plans.

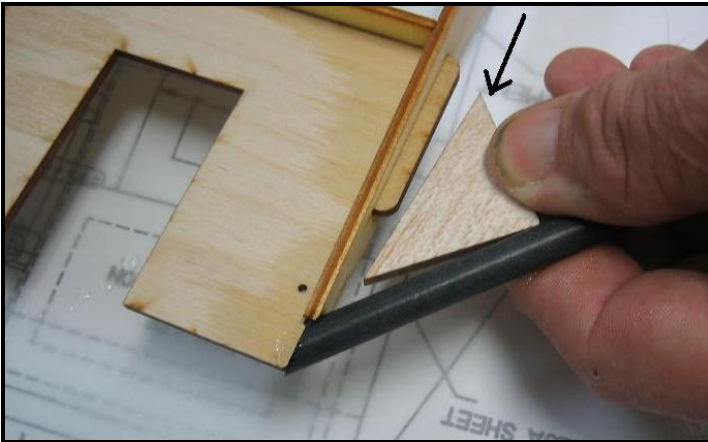

Note: the forward gusset should be installed underneath the protruding tab from the motor mount while the airframe is in the upright position.



Next glue the triangle gussets, that are positioned behind the L.E. and on the outside of the #2 ribs, with thick CA.

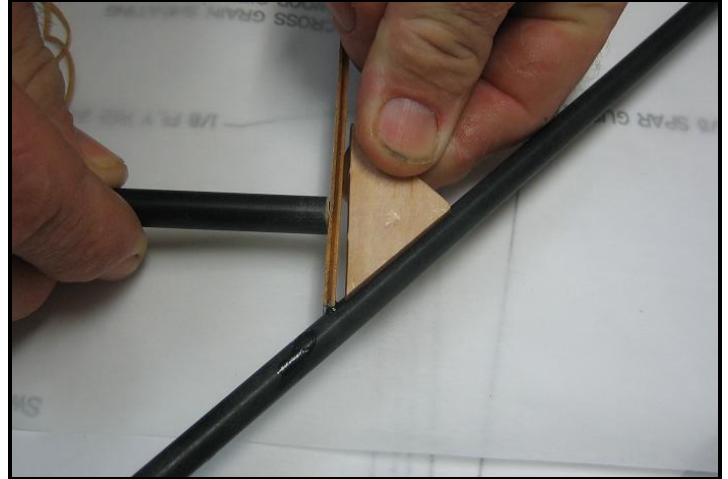

NOTE: make sure you glue both the top and bottom sides of gussets where they connect to the leading edge and ribs.

Now add the motor mount doubler plate to the bottom of the motor mount. Glue in using thick CA all around the bottom of the motor mount and clamp tight until the glue dries.

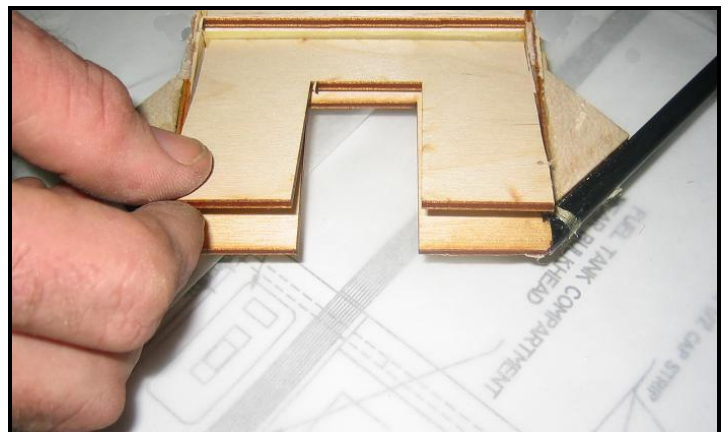

Section 1: Framing of the Airframe – Cont.

□ Step 16

Locate the two precut 1/4"x1-1/2" elevon stock / balsa wing tips, with the 38 degree angle on one end, and place the square end between the TE cap strips with the 38 degree angle cupped into the rear side of the leading edge on the outside of rib #3. Glue in place first with thin CA and then add thick CA where the balsa meets the backside of the L.E. Repeat this step for both sides. NOTE: **Do not glue the 1/16 x 1/2 "cap strips on the trailing edge assembly yet!**

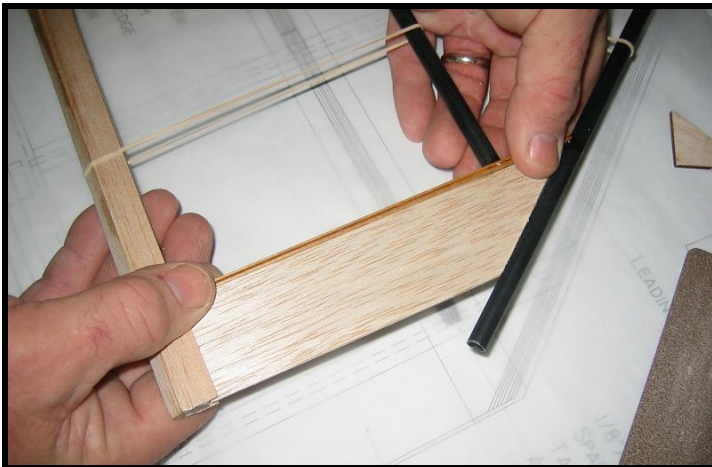

□ Step 17

Locate the Kevlar thread in the parts bag. Following the illustrations on the print, first wrap the #2 and #3 ribs where they intersect the L.E. Make sure you reference the print first before starting, to ensure that you will be installing the Kevlar at the proper angles.

Place a drop of thin CA on the spar tube and lay the tip of the Kevlar thread in the glue drop and allow it to dry. This will hold the Kevlar in place while you wrap the thread around the ribs and L.E. and spar.

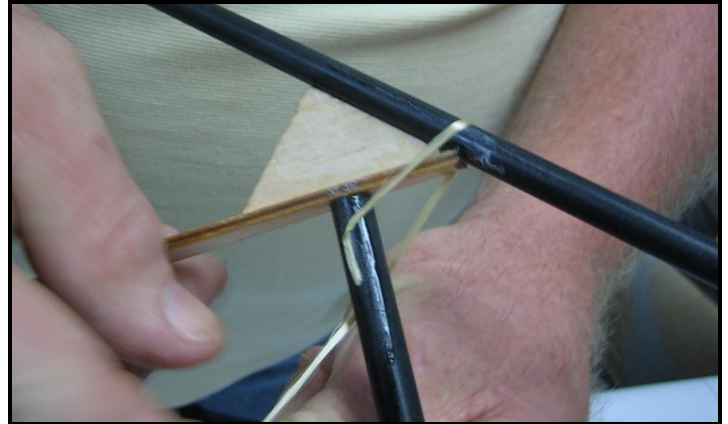

Next, wrap 5 to 6 turns around the rib, L.E. and spar, while holding the Kevlar thread tight.



Once wrapped, soak the entire Kevlar thread with thin CA. Repeat this step for all four points where the ribs and L.E. intersect, as shown on the print. NOTE: You can now cut the four rubber bands that hold the leading edge tubes.

Section 1: Framing of the Airframe – Cont.

□ Step 17 – Cont.

Next, thread the Kevlar through one of the small laser cut holes found on the motor mount and wrap it around the leading edge and motor mount 5 or 6 times while reinserting it through the laser cut hole. Glue it in with thin CA.

NOTE: you may have to re-drill the holes since the laser cut hole may have been filled in with glue from step 15

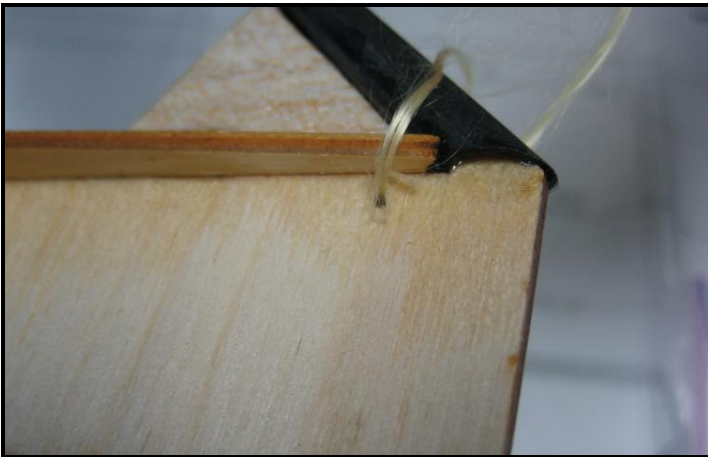

Repeat this for both sides of the motor mount.



□ Step 18

Trim the .300 E glass tube flush with the wing tip (*Hack saw, razor saw, 9+ or band saw works well for this; a fine file will also do the job*).



After cutting off the extra tubing from both L.E. tubes, sand the ends down flush to the 1/4"x1-1/2" elevon stock / balsa wing tips.



Section 1: Framing of the Airframe – Cont.

□ Step 19

Now separate the unglued portions of the cap strips at the ends of the T.E. assembly.

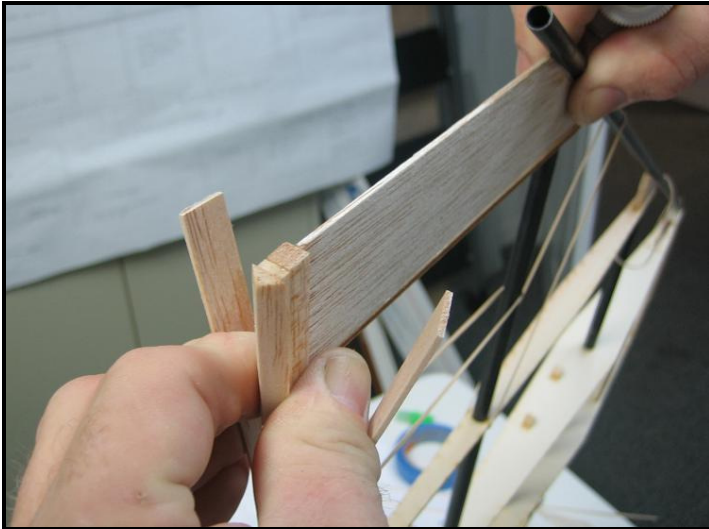

Next, place a small piece of balsa stock or a pencil in between the cap strip and the $\frac{1}{4}$ " x $\frac{3}{8}$ " T.E. stock to keep the cap strip elevated. Sand the trailing edge to match the taper of the wing tip balsa stock. Repeat the sanding and shaping of the T.E. for both top and bottom of the T.E assembly on both sides of the airframe.



When you have finished shaping both sides of the T.E., glue the cap strips down to the tapered T.E assembly on both sides of the airframe.



Your cap strips and trailing edge should look like the photo below when completed.



Section 1: Framing of the Airframe – Cont.

□ Step 20

Apply cap strips to both top and bottom of the #3 ribs on both sides of the airframe.

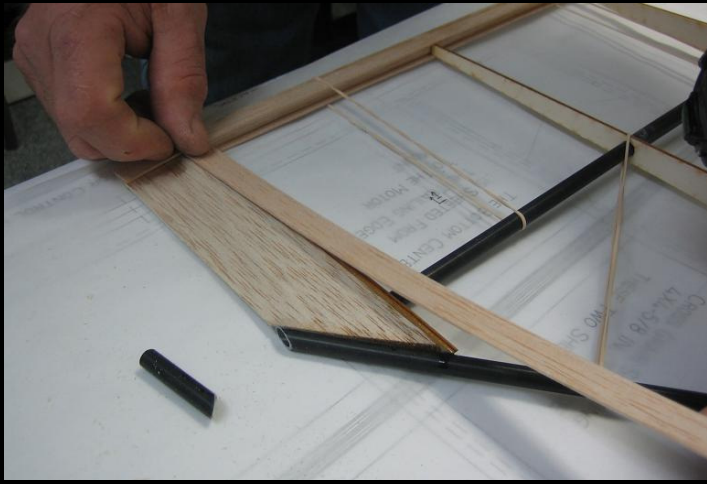

Trim the cap strip with a hobby knife or scissors to match the angle of the L.E. tube.

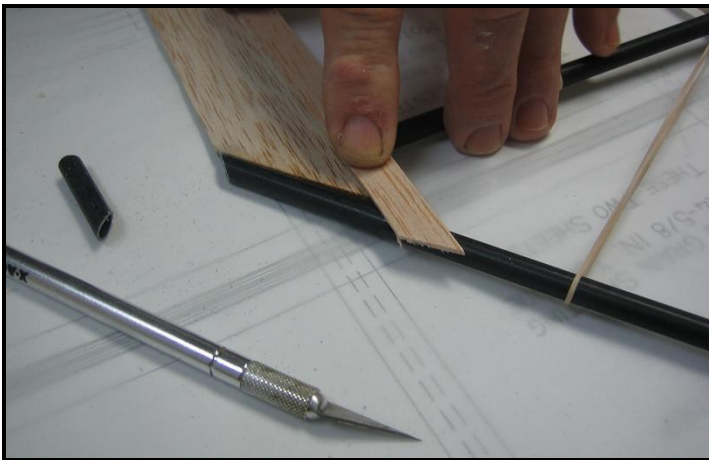

□ Step 21

Next, locate the leading edge hardwood coving stock and apply one piece to each of leading edge tubes with thick CA. Start at the motor mount and apply rearward. Make sure to leave a little at the motor mount so you can cut and sand to shape later.

Note: Take care to apply the coving as straight as you can on the L.E. tubes.

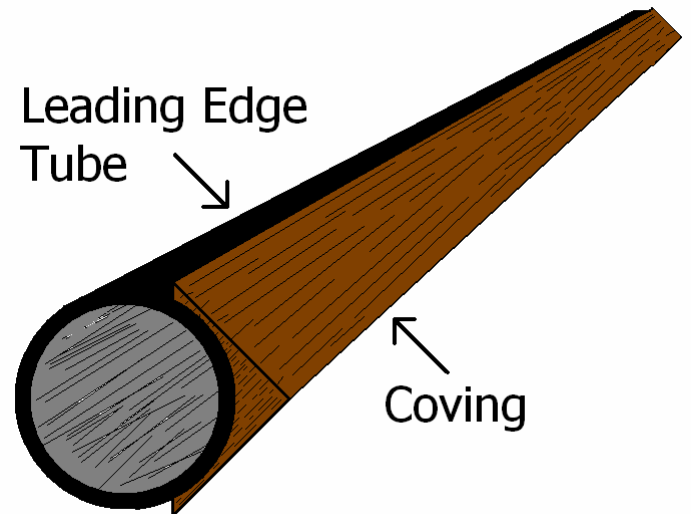

Section 1: Framing of the Airframe – Cont.

Step 21 – Cont.

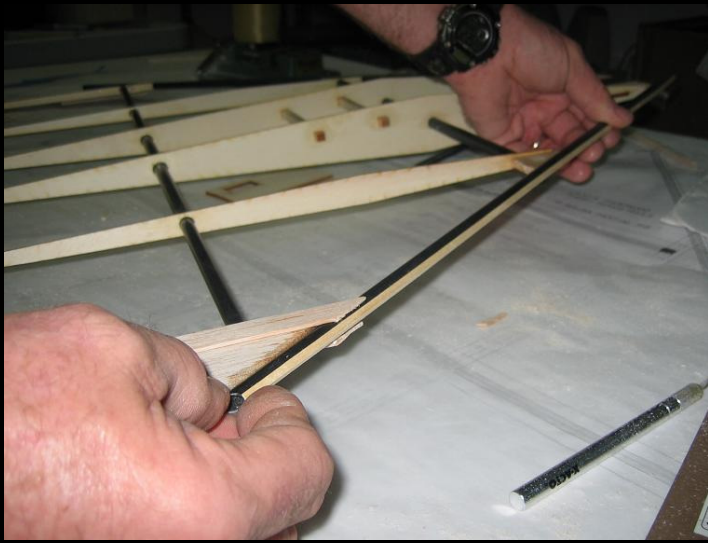

Cut each piece of coving stock flush with the tip of the L.E. tubes and the motor mount, then sand lightly.

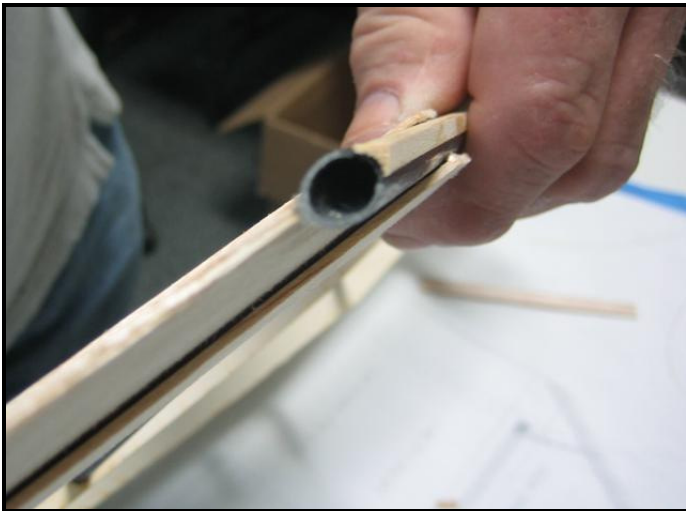

Step 22

Now cap strip the outer edge of both the balsa wing tips from the L.E. tubes back to the T.E. Leave a little extra at both ends for shaping.



When dry, sand down the end cap strip so it tapers from the L.E. tube back to the T.E. assembly.

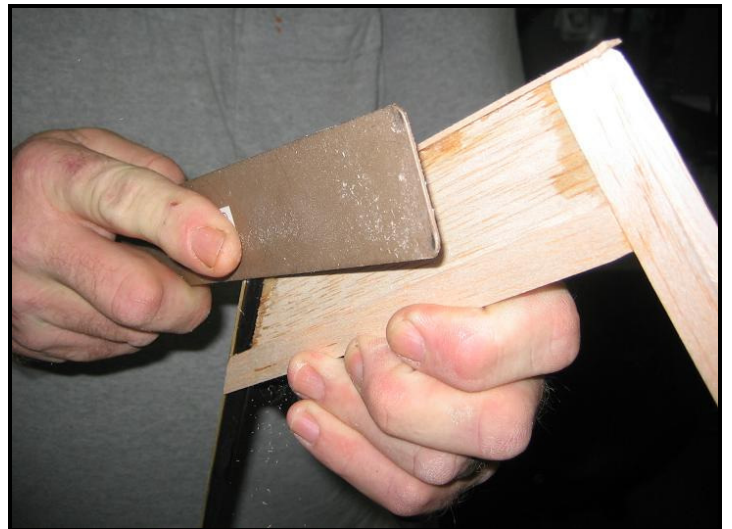

Section 1: Framing of the Airframe – Cont.

□ Step 22 – Cont.

The taper should be strait and consistent towards the T.E.



Next, sand the cap strip over the #3 rib so it flares around the L.E tube assembly. **NOTE:** be careful to not sand through the Kevlar thread that is wrapped around the L.E and the #3 rib.



When sanding is complete, fill any gaps with thick CA.

□ Step 23

Install a 1/16" x 1/2" cap strip to the top and bottom of the #2 ribs using thick CA.

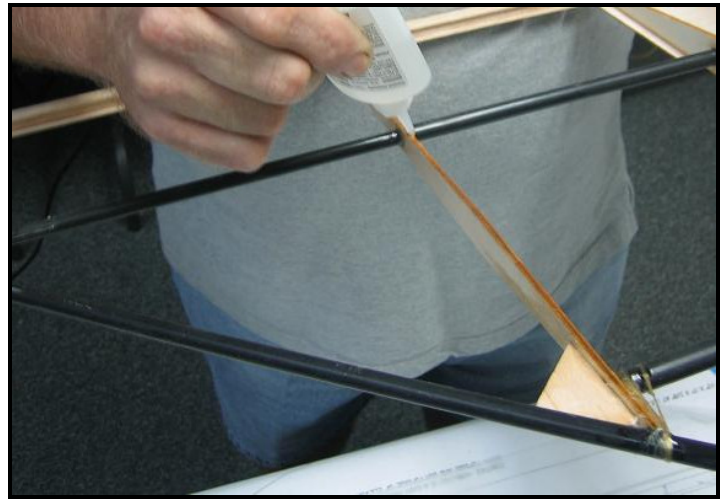

When you have both the top and bottom cap strips installed on the #2 ribs, cut the cap strip at the same angle, but a little longer than the L.E tubes.

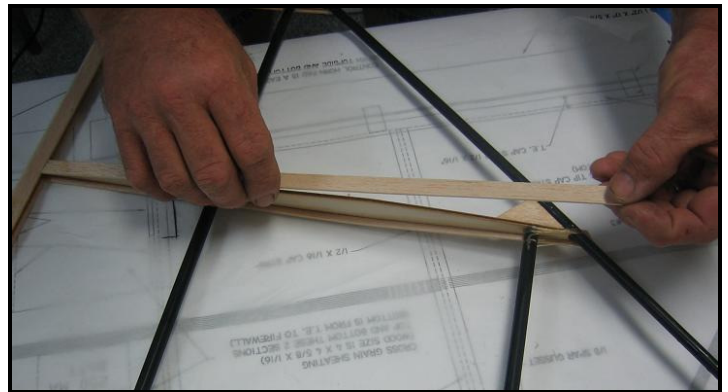

Then, sand and fill the gaps at the L.E. the same way as shown for the #3 ribs in step 22.

Section 1: Framing of the Airframe – Cont.

□ Step 24

NOTE: when installing the hardwood rails, pay close attention to the direction of the grain by looking at the end of the rails before inserting them into the ribs. The grain should go fore and aft and NOT up and down.

← Grain →

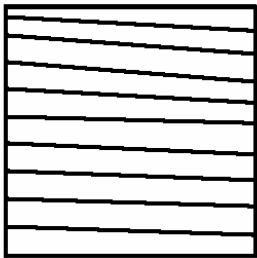

Correct !

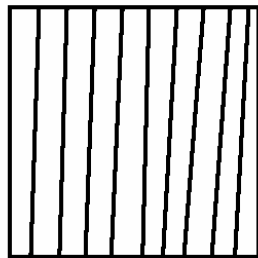

Incorrect!

At this point, install your servo rails.

Take the 1/4" x 1/4" x 4-3/8" hardwood servo rails and slide them through the square holes. Check to make sure your servos fit. If your servos do not fit, make an adjustment on the rear hole at this point. The output shafts of the servos should be completely above the ribs and sheeting.

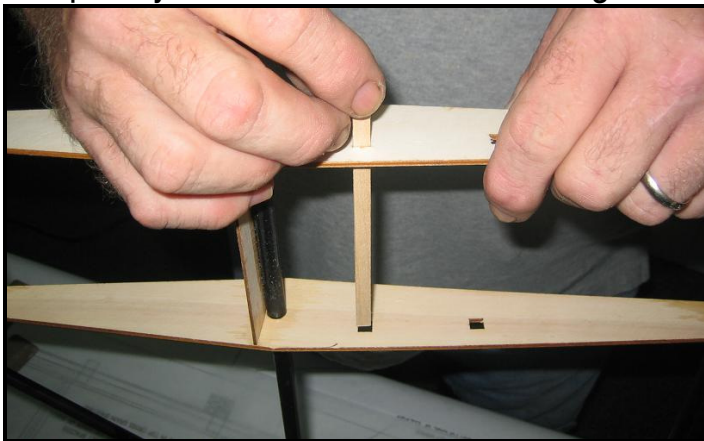

Glue the servo rails in first using a drop of thin CA between each servo rail and each #1 rib. **Note:** Center the rails so you leave approximately 1/4" sticking out on the outside of both ribs.

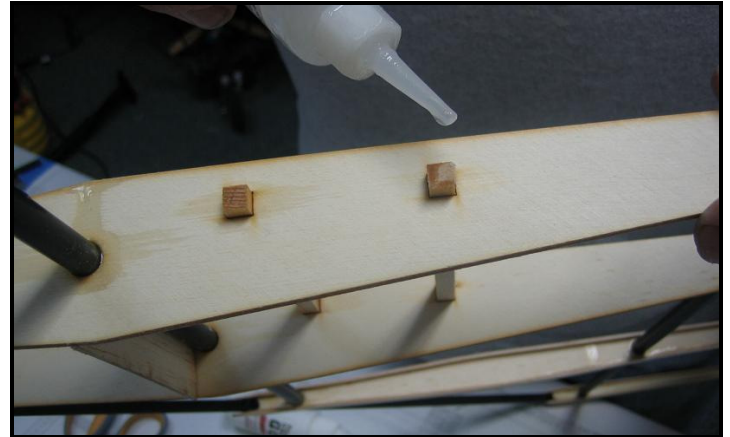

When you have finished applying the thin CA, apply a bead of thick CA around the rails on both sides of each rib.

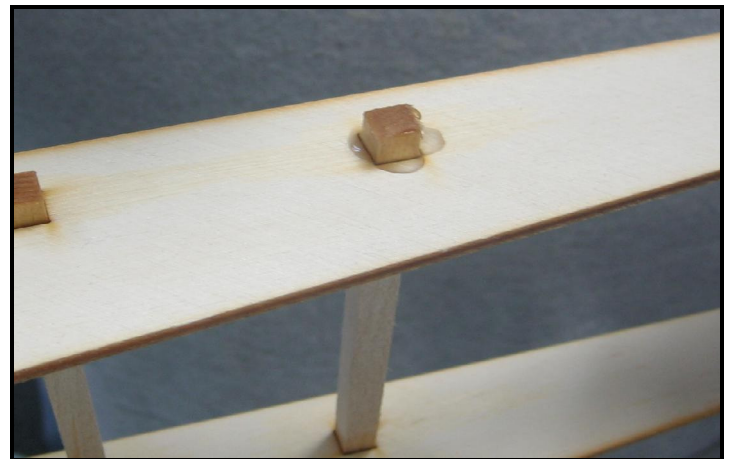

Section 1: Framing of the Airframe – Cont.

□ Step 24 – cont.

Once you have both servo rails glued in, you will need to pre-drill your servo mounting holes. Note: Position the servos so you leave approximately 1/16" between the #1 rib and the side of the servo.

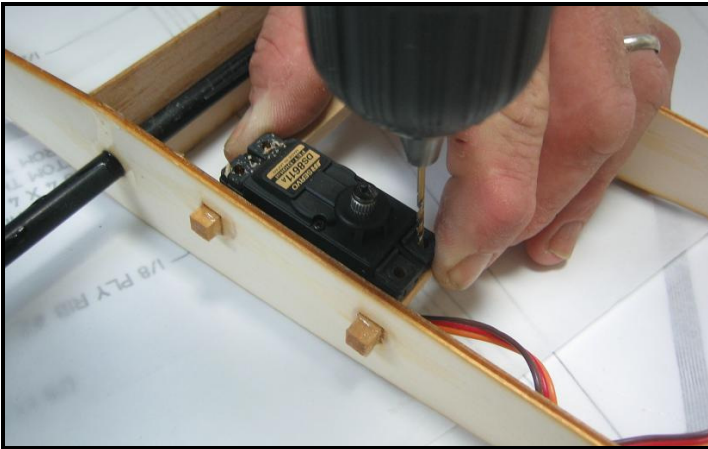

Once you are done with pre-drilling the servo mounting holes, remove the servos and set them aside. You will not need them until section 7.

□ Step 25

Next find the 4" x 4-5/8" x 1/16" Balsa sheet with precut slots and glue it at the trailing edge of the aircraft on the topside of the airframe using thick CA.

NOTE: Make sure the slots are at the T.E and NOT facing the front of the airframe when installing.

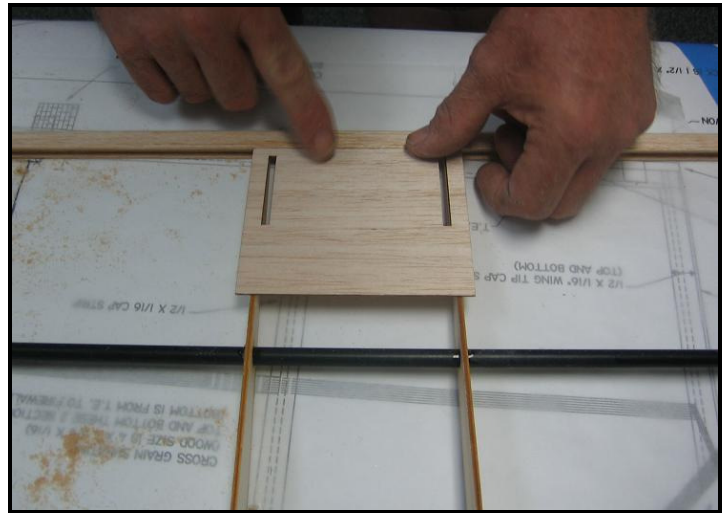

Next, turn the airframe over (*bottom side up*) and locate two of the 1/8" x 1/8" x 4" balsa fin offset spacers. Align the spacers so they butt up to the T.E. and are aligned to the bottom edge on the inside of the #1 ribs. Repeat this step for both spacers.



Section 1: Framing of the Airframe – Cont.

□ Step 25 – cont.

With the airframe bottom side up, install the 4" x 4-5/8" x 1/16" balsa center sheeting, beginning at the TE and going towards the nose, using thick CA.

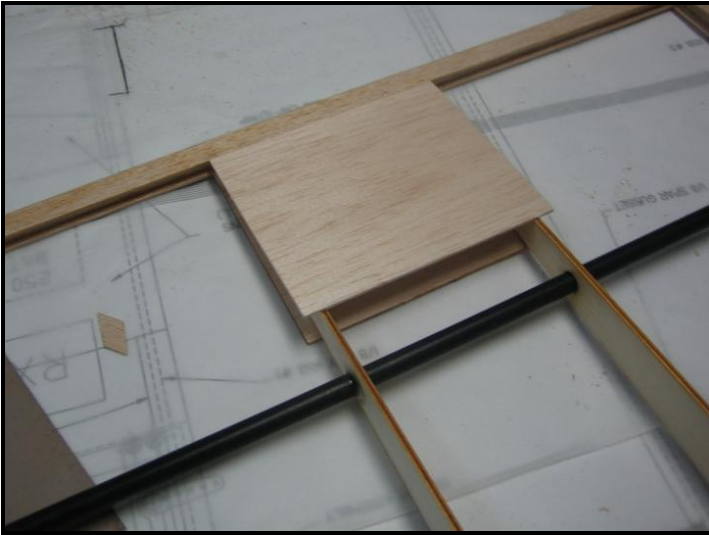

After applying the second cross grain sheet, you will need to determine if you will be using a standard radio receiver or a spread spectrum receiver.

If you will be using a spread spectrum receiver you may skip the rest of step 23 and proceed to step 24.

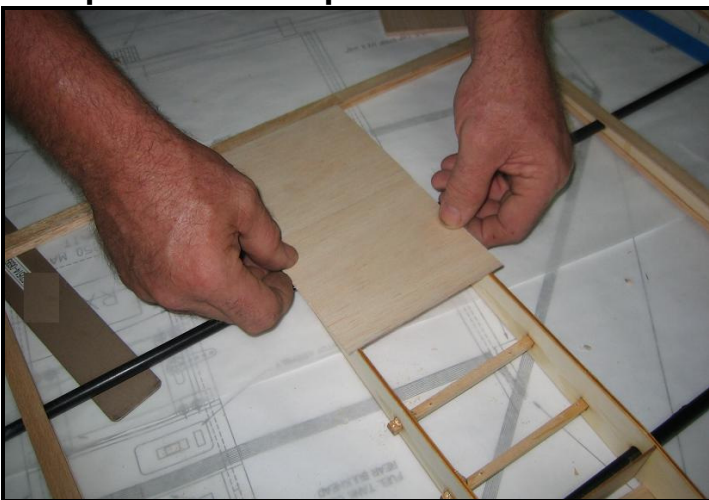

□ Step 26

The antenna tube will be inserted in the four precut 3/32" holes found on both of the main ribs. You will need to feed the antenna tubing through the front holes first. As shown below.

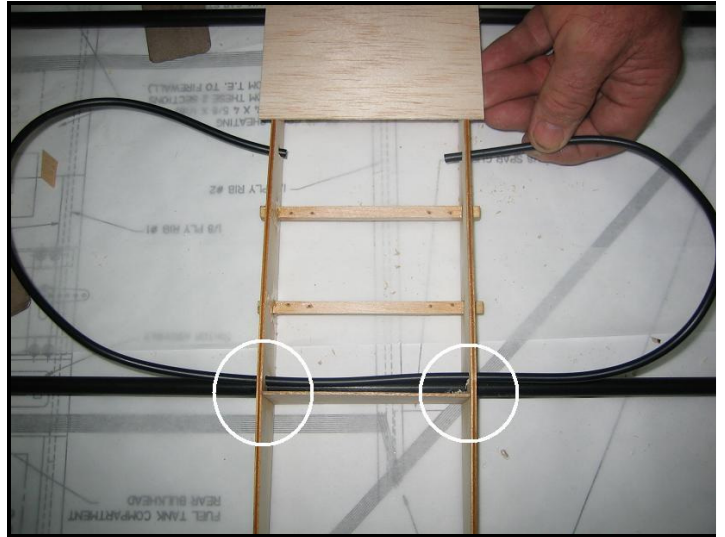

After centering the tubing through the front holes, insert the remaining portion of tubing in the rear holes.

Remember: the airframe should still be upside down.

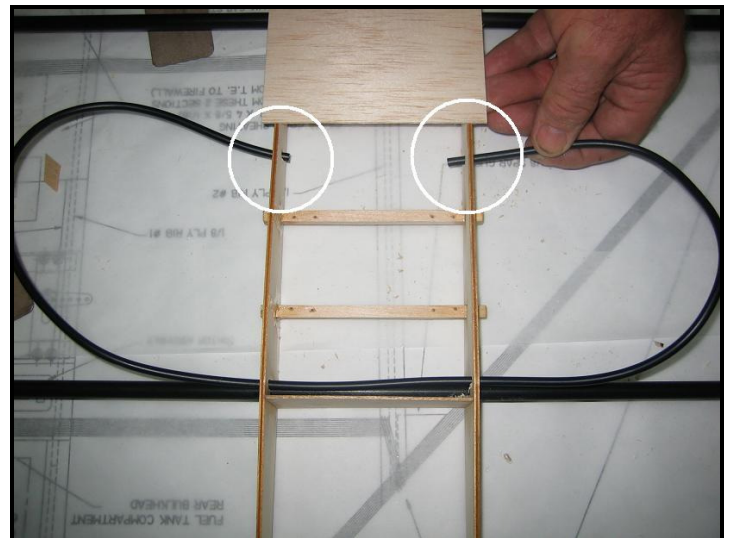

Section 1: Framing of the Airframe – Cont.

Step 26 – cont.

Leave approximately $\frac{1}{4}$ " to $\frac{1}{2}$ " of the tubing protruding through the #1 ribs. Next, glue the tubing in with thin CA then thick CA, on both sides of every hole the tubing intersects.

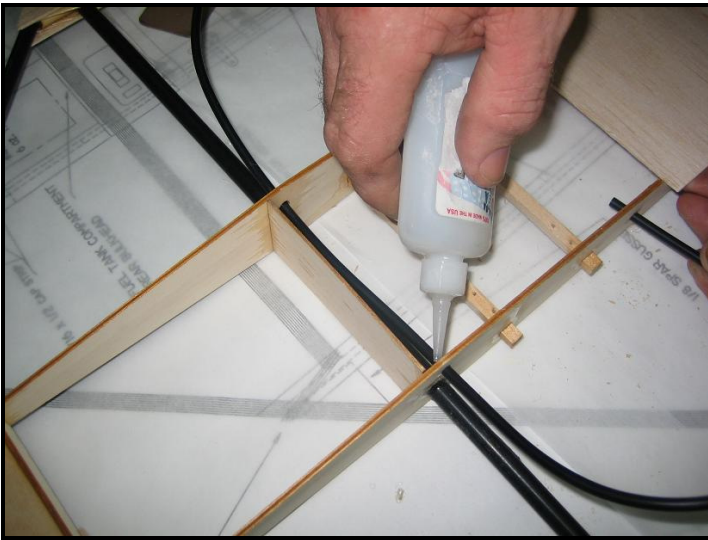

Step 27

Continue to apply the rest of the cross grain sheeting on the bottom of the airframe. The last piece should stop at the firewall (*it will have to be trimmed*).

Then, turn the airframe over and apply one more cross grain sheet to the topside of the airframe, in front of the fin cross grain sheet, for a total of 8" of sheeting in front of the trailing edge of the aircraft.



Section 1: Framing of the Airframe – Cont.

□ Step 28

Next you will cut pieces of ¼" x ¼" triangle stock to fit on the inside area of the motor mount plate.

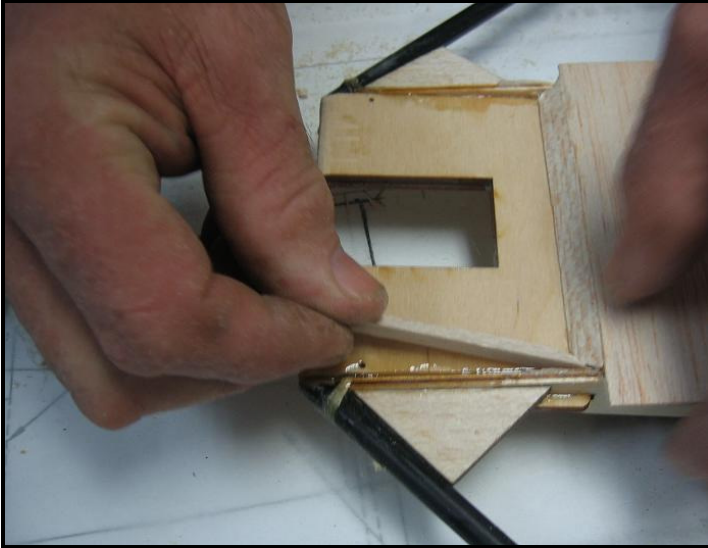

Miter your corners at 45 deg. angles for best fit. You may have to notch the triangle stock to clear the Kevlar thread that is wrapped around the motor mount plate and the L.E.

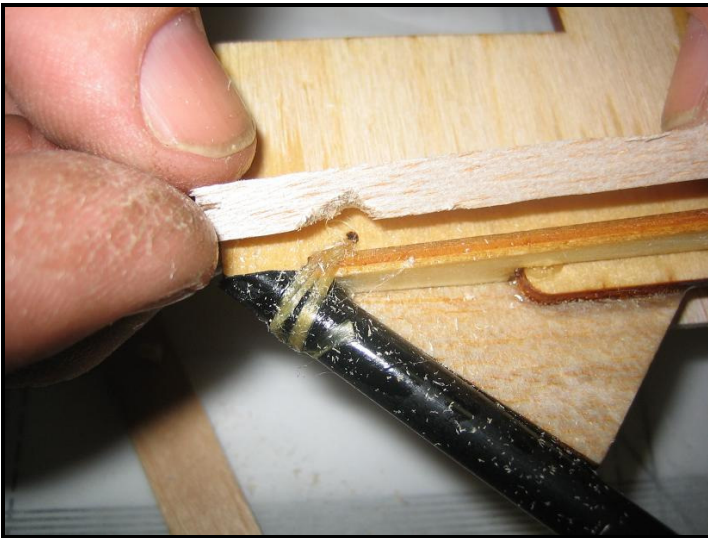

Repeat this procedure for both the top and bottom of the motor mount plate.

With a hobby knife, trim the triangle stock to match the #1 rib profile.

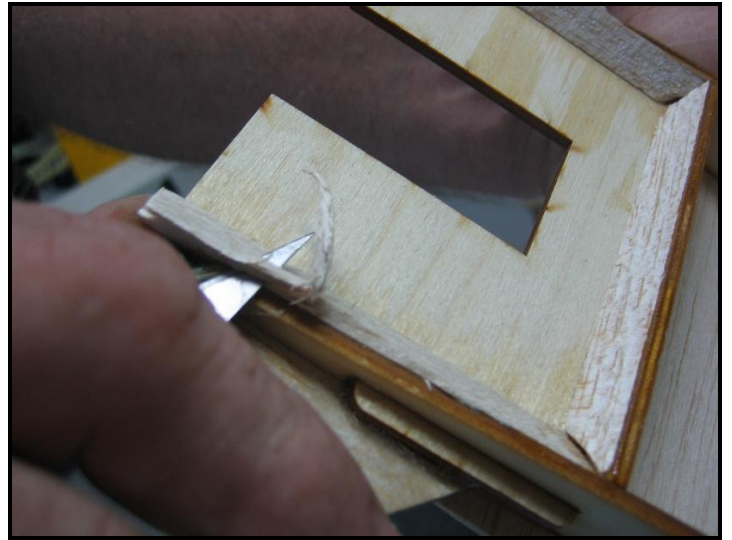
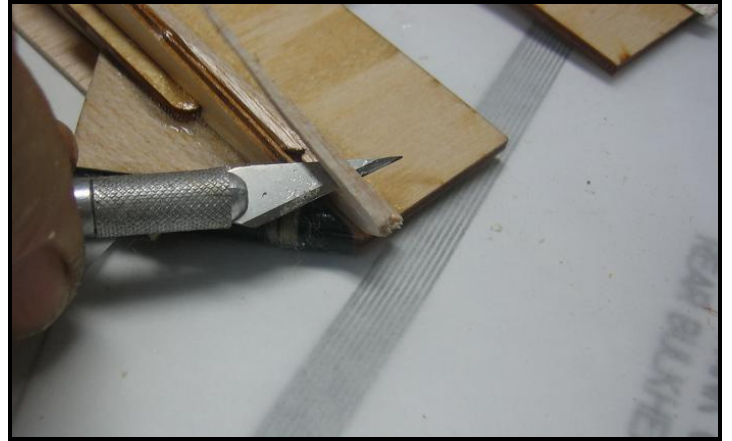

When you are done trimming the triangle stock for both the top and bottom of the motor mount, lightly sand the triangle stock to match the ribs and firewall.

Section 1: Framing of the Airframe – Cont.

□ Step 29

Locate the 1/8" x 3-7/8" x 1-3/4" plywood switch plate and apply thick CA to the sides and front part of the switch plate.

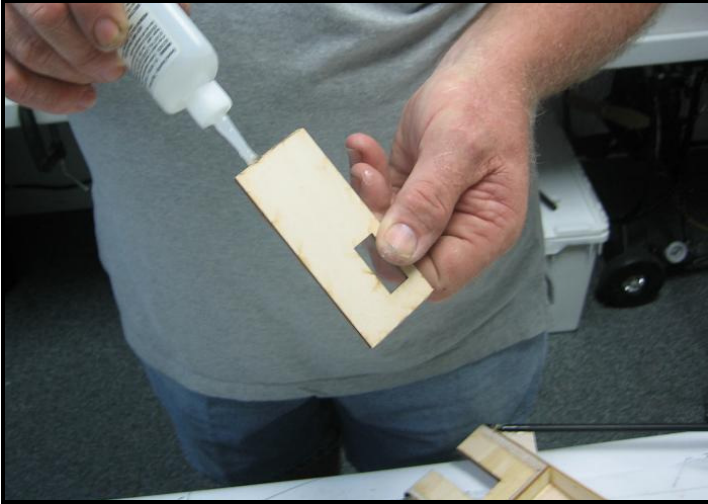

Refer to plans for proper orientation and glue the switch plate so it is even with the side of the ribs.



□ Step 30

Locate the two 1/4" x 1/4" x 7/8" hardwood throttle servo rails. Pre-mount the throttle servo to the short servo rails (this will be used to set the spacing between the #1 rib and the partial rib).

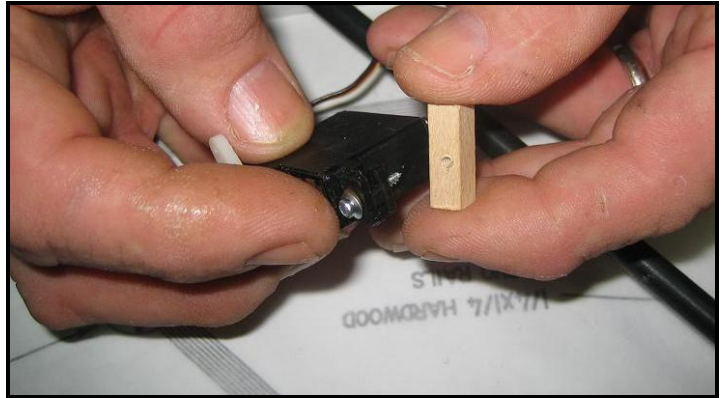

Next, determine which side of the fuel tank compartment your throttle servo will need to be positioned by which side of your motor the carburetor linkage is located.

Place a drop of thick CA on each end of the hardwood servo mount rails and install the throttle servo as far forward as possible. There should be enough room for the servo arm to clear the top of the ribs and future cap strips.

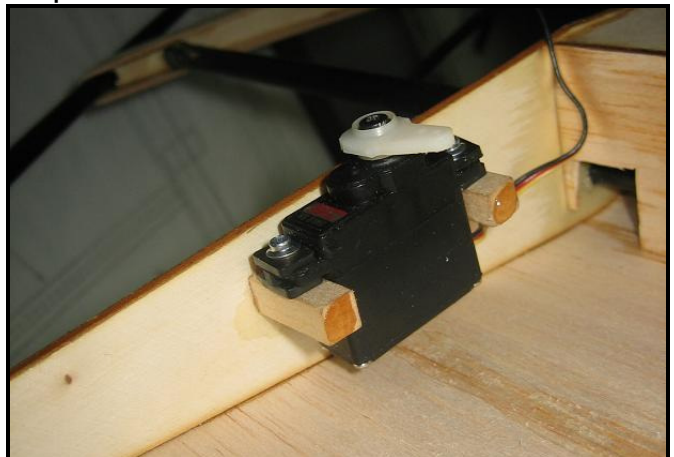

Section 1: Framing of the Airframe – Cont.

□ Step 30 – cont.

Once you have determined which side the throttle servo will be mounted, cut a small $\frac{1}{4}$ " x $\frac{1}{4}$ " hole in the $\frac{1}{16}$ " bulkhead to allow for your throttle servo lead to be passed rearward into the radio / elevon servo compartment.

NOTE: Make sure your hole does not reach over more than $\frac{7}{8}$ " from the rib.

Place a drop of thick CA on the end of each hardwood servo mount rail.

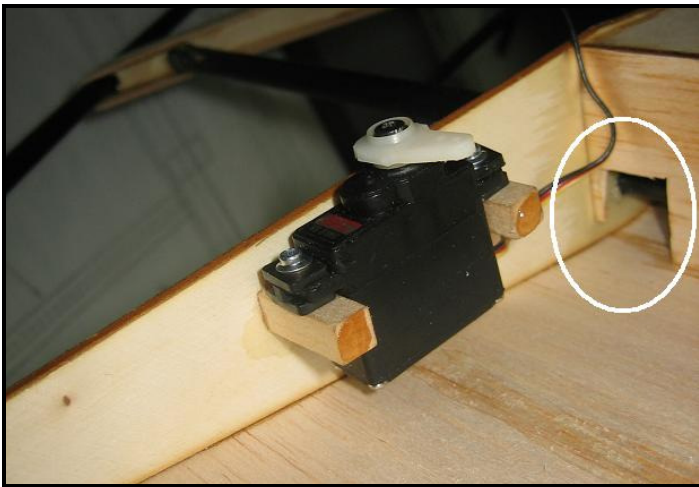

Locate the $\frac{1}{16}$ " balsa partial rib and insert it between the firewall and the fuel tank rear bulk head, while pressing it up against the throttle servo and hardwood servo mount rails that have thick CA on them.

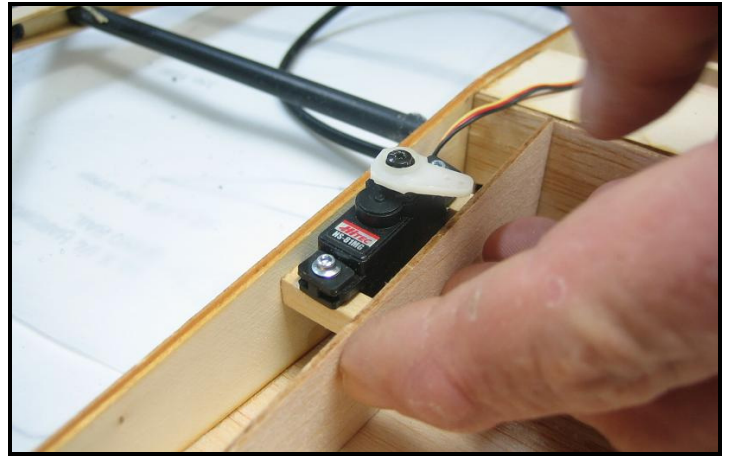

Finish gluing the partial rib in, using thick CA.



When the glue is dry, remove the throttle servo and set it aside until Section 5.

Section 1: Framing of the Airframe – Cont.

□ Step 31

Locate a piece of 4" x 4-5/8" x 1/16" balsa cross grain sheeting and cut it to match the plywood switch plate. Then glue it in using thick CA.

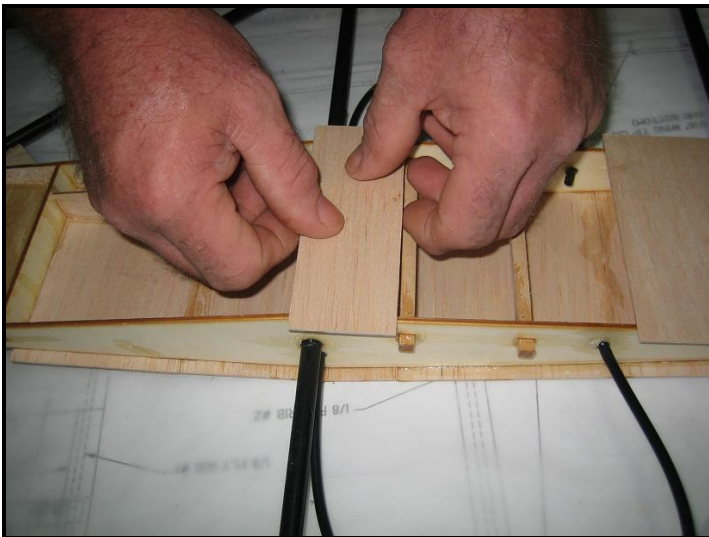
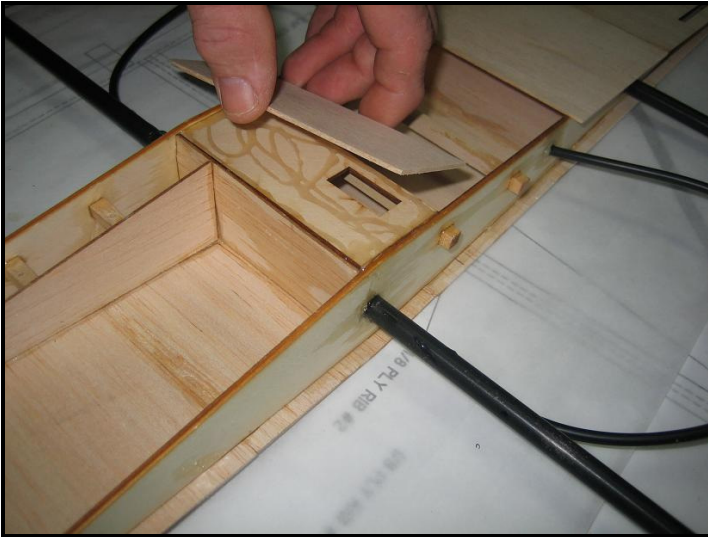

□ Step 32

Cut-to-fit two 1/16" x 1/2" cap strips to fit over both #1 ribs, between the newly covered switch plate and the cross grain sheet where the elevon servos are mounted.

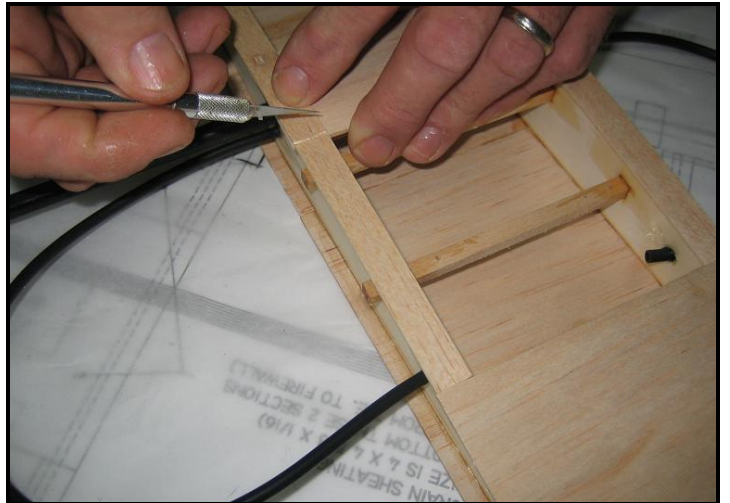
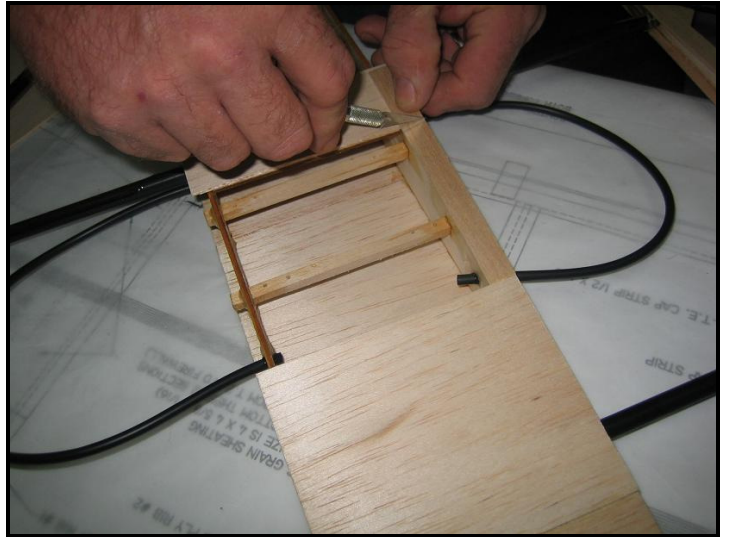

Section 1: Framing of the Airframe – Cont.

□ Step 32 – cont.

NOTE:!!!

The next step is determined by what size engine you will be using. If your engine is a .28 or smaller you will place the fuel tank against the rear bulkhead of the fuel compartment. If your engine is a .30 or larger you will position the fuel tank up against the plywood fire wall. This assembly manual and the plans show the assembly for a .30 or larger engine.

If you are installing a .28 or smaller, you will reverse the 1/16" x 1/2" x 4-5/8" cap strip and the 1/16" x 2" x 4-5/8" sheeting as shown below.

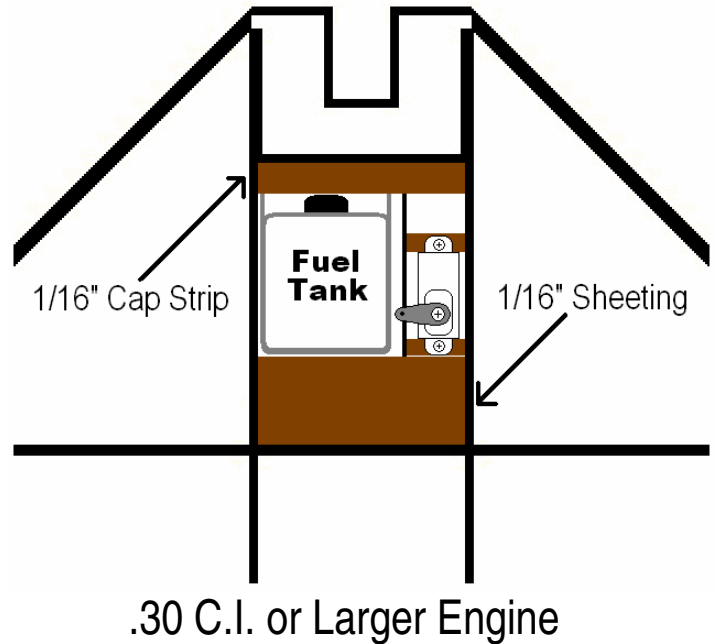
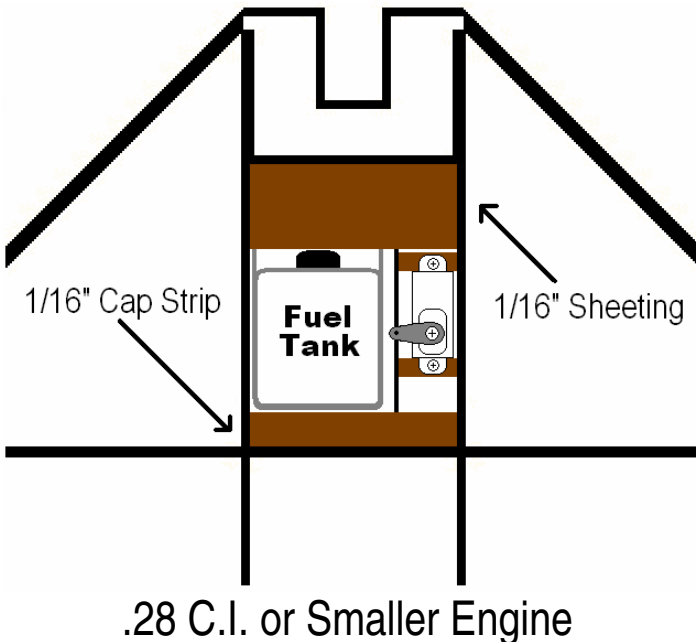

Install the 1/16" cap strip across the main ribs, at the plywood firewall, with thick CA. This cap strip will also help lock in the fuel tank when the fuel tank is installed.

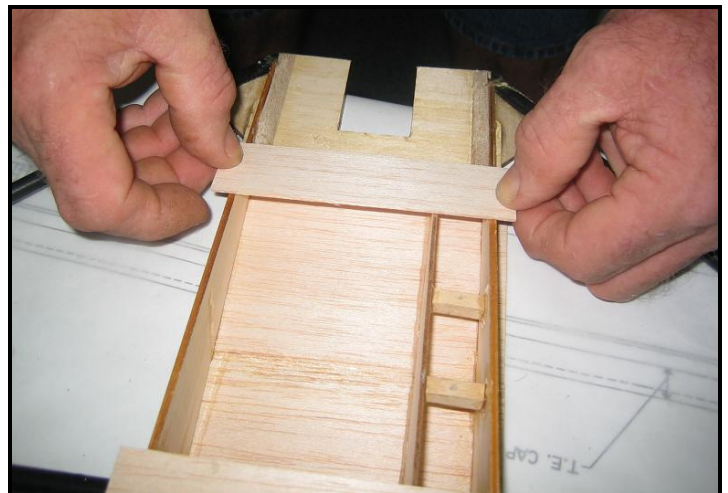

Section 1: Framing of the Airframe – Cont.

□ Step 32 – cont.

Next apply 1/16" cap strips to both #1 ribs between the switch plate and firewall.

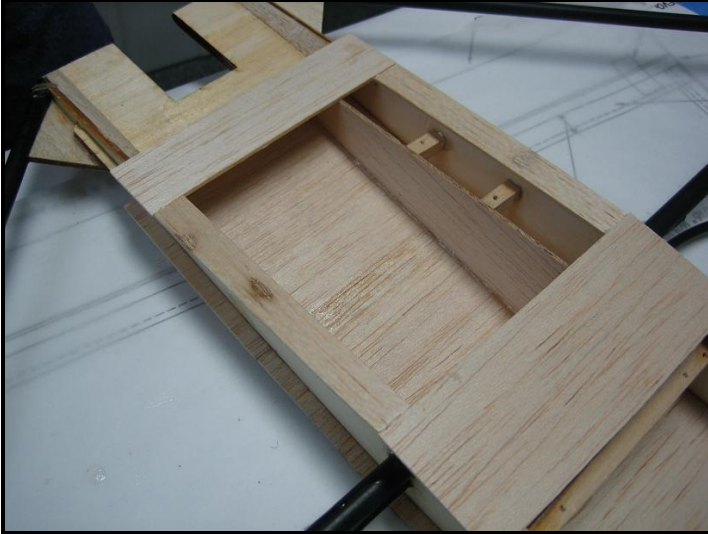

Apply two more cap strip pieces to the #1 ribs in front of the firewall leading up to the front of the motor mount.

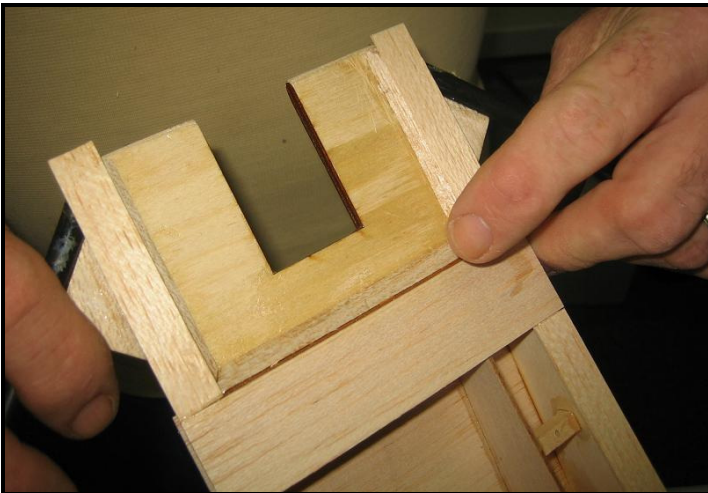

Cut the scrap 1/16" x 4-5/8" to fit the throttle servo and fuel tank area.

Add another piece of 1/16" cap strip to the partial rib in the fuel tank compartment. Remember to apply all cap strips with thick CA.

Make sure to check that you have clearance for the throttle servo arm.

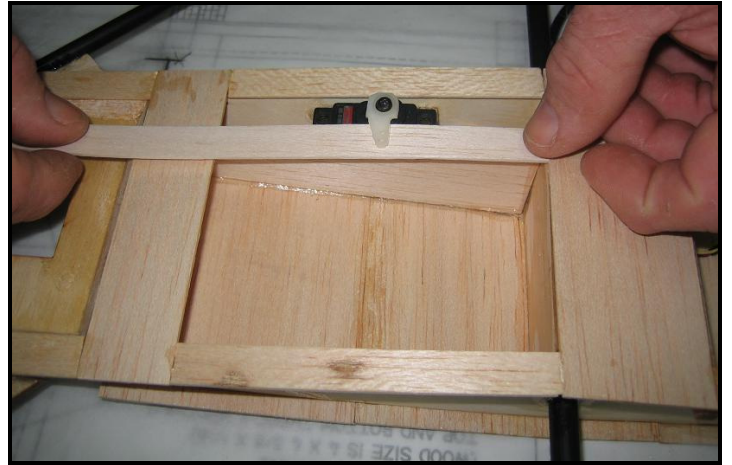

Turn the airframe over and apply the 1/16" cap strips to the front of the #1 ribs at the motor mount plate.

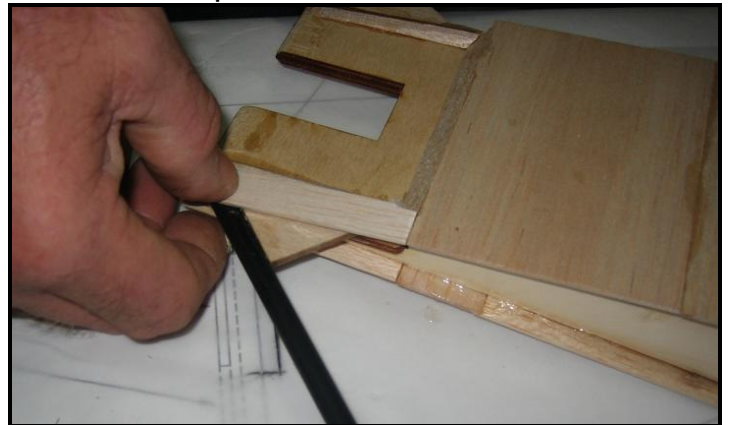

Section 1: Framing of the Airframe – Cont.

□ Step 32 – cont.

Sand all the cap strips at the LE, and any rough edges, being careful not to sand through the Kevlar thread.

NOTE: you can also at this time, taper the motor mount and doubler by sanding them to a taper at the L.E of the motor mount.



Also, fill any holes or pockets around the engine mount and LE with thick CA or sawdust and CA.

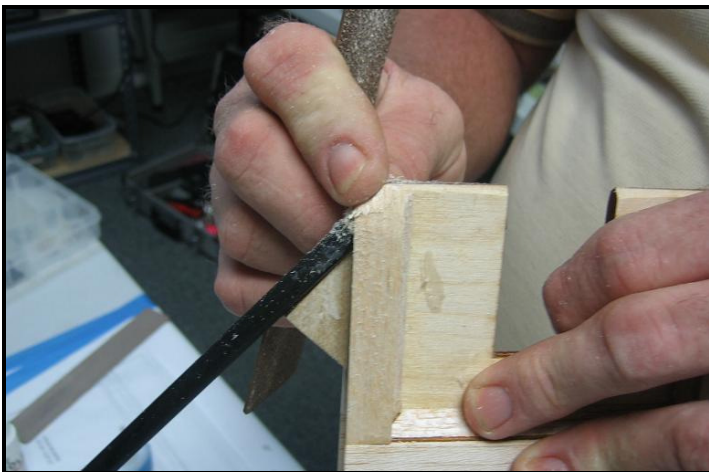

Also, don't forget to seal any spaces found around the cap strip and the motor mount/firewall area.

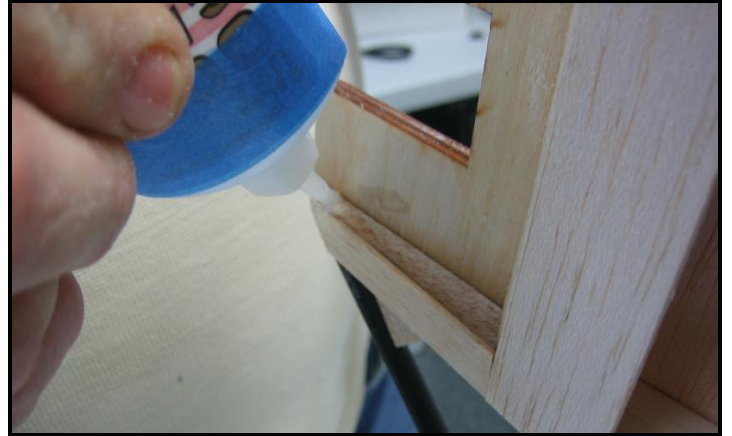

Lightly sand all wood surfaces and wipe the airframe clean. Set the airframe aside and proceed to Section 2.

Section 2: Elevon Construction

Step 1

Locate the two precut balsa elevons from the box. Please take note that the elevon stock is NOT symmetrical. Make sure to orient both elevons with the 90 deg. corners in the up position as shown below.

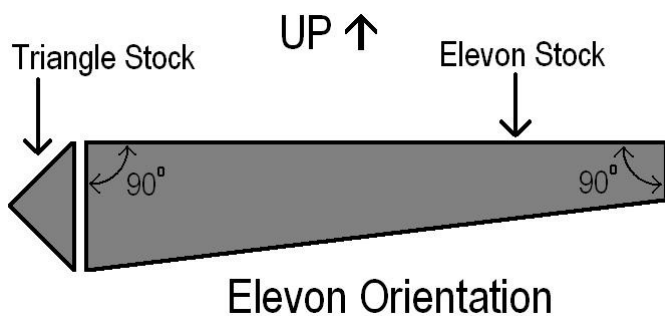

Step 2

Next, locate a full length of 1/4" x 1/4" triangle stock and cut two pieces slightly longer than each elevon, making sure to leave approximately 1/8" extra on both ends of the elevons for later sanding.

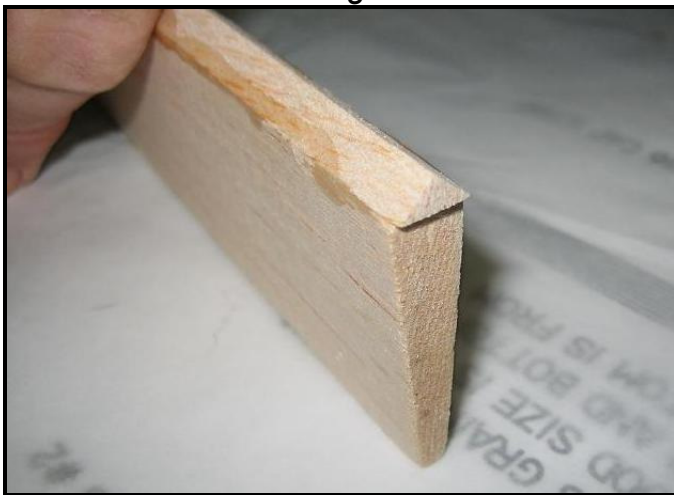

Step 2 – cont.

Glue the triangle stock, first using thick CA and then applying thin CA



Note: you can trim the triangle stock easily with a pair of scissors or hobby knife.



Section 2: Elevon Construction – Cont.

□ Step 3

Next, sand both ends of the elevon triangle stock flush with the ends of the elevon stock. You will also need to taper the trailing edges of the elevons for cleaner airflow

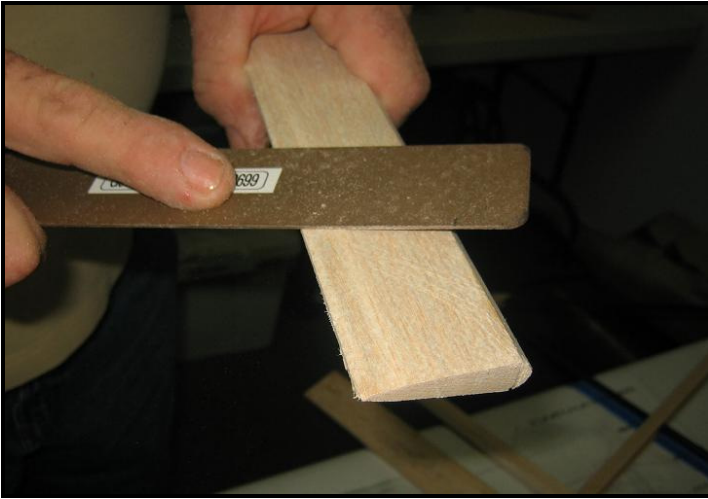

Your end profile of the elevons should look like the diagram below.

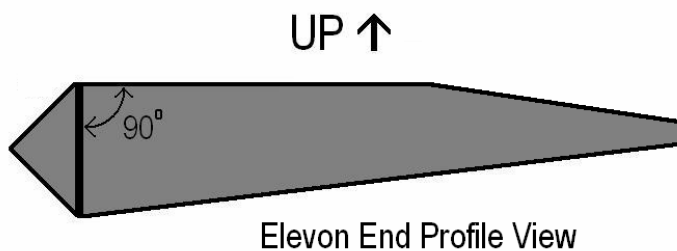

□ Step 4

With the airframe and elevons on the print, mark all hinge locations on both the elevons and airframe with a pencil, as indicated on the plans.

Use your hobby knife or hinge slot tool and cut the six hinge slots on the trailing edge of the airframe as well as the six matching slots on the leading edges of both elevons.



Once hinged, insert the CA hinges on the slots on the elevons and install both elevons to the trailing edge of the aircraft. Make sure to align the outside edges of the elevons to be flush with the outside wing tip.

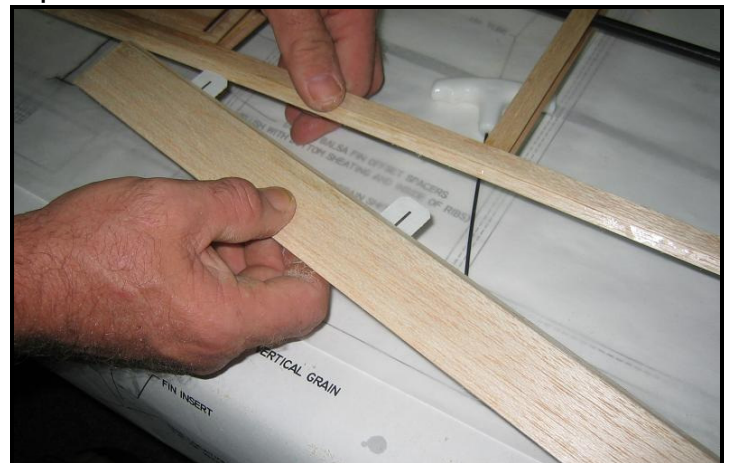

Section 2: Elevon Construction – Cont.

□ Step 5

Bend each elevon to full deflection (about 90 deg.). Be careful to not bend so far as to pull the elevons and trailing edge apart.



Allow the elevons to return to neutral position. Be careful not to lose the full deflection spacing that you just set. There should be an even spaced gap all the way down the elevon and trailing edge (approx. 1/16").



With the airframe lying on the table, soak each CA hinge with thin CA. Allow your first glue application to dry, then apply glue to both the top and bottom of all the hinges.

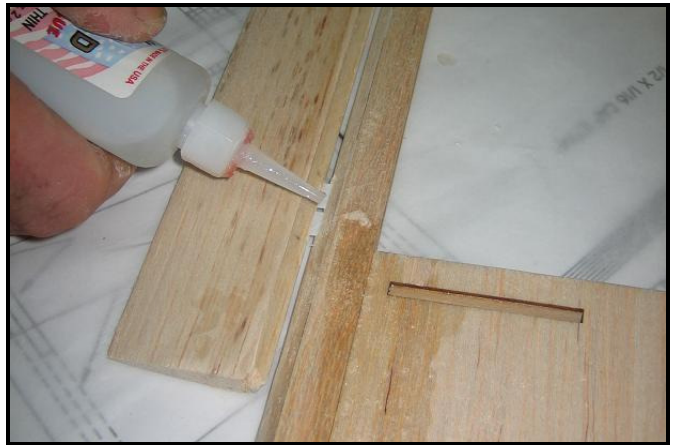

Next, place a CA hinge on the top of the elevon as a "re-enforcement pad" for the control horn, as per the plans. Once in position, apply thin CA to the entire "pad" and allow the glue to dry completely before doing the same to the bottom of the elevons.



Section 2: Elevon Construction – Cont.

□ Step 5

Next, while using a sanding block or file, taper both outside elevon ends to match the tapered wing tips.



NOTE: Be sure to match the taper of the balsa wingtips as closely as possible. Taper the elevons only in the tapered zone shown below.

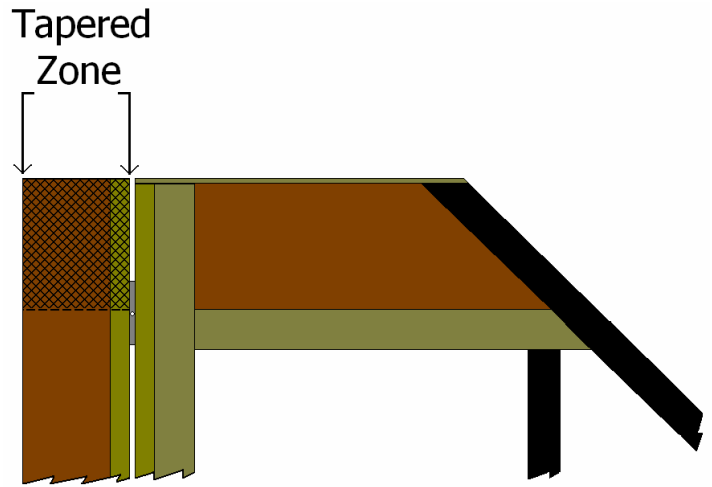

Your tapered elevons should look like this, when completed.



Elevon Taper
(Rear View)

Section 3: Vertical Fin Assembly

Step 1

Cover a clean flat surface with wax paper or parchment paper and then glue the front and rear halves of the fin assemblies, as shown on the blueprint, using thick CA.

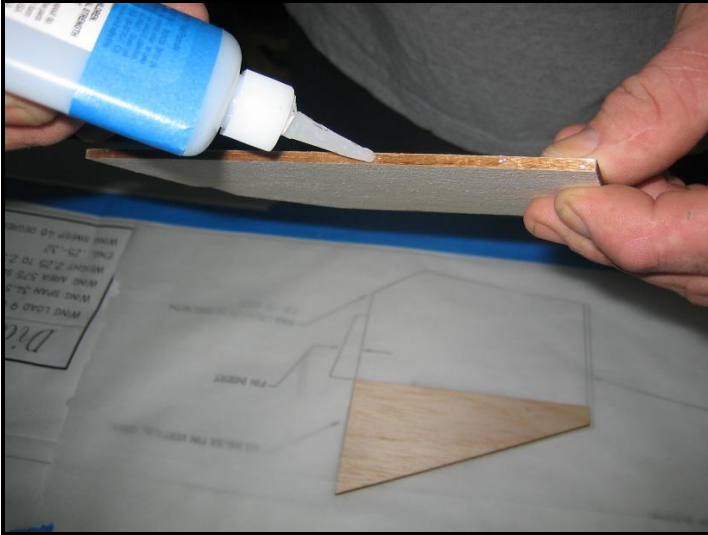

Remember to keep the fins as flat as possible while the glue dries.



Step 2

Next, locate one of the 1/8" x 1/8" x 4" balsa fin offset fin cap strips. Install them to the top of the fin as a cross grain cap strip.



NOTE: Repeat steps 1 and 2 to make two fins.

Step 3

Sand both leading and trailing edges of the fins, for less drag.

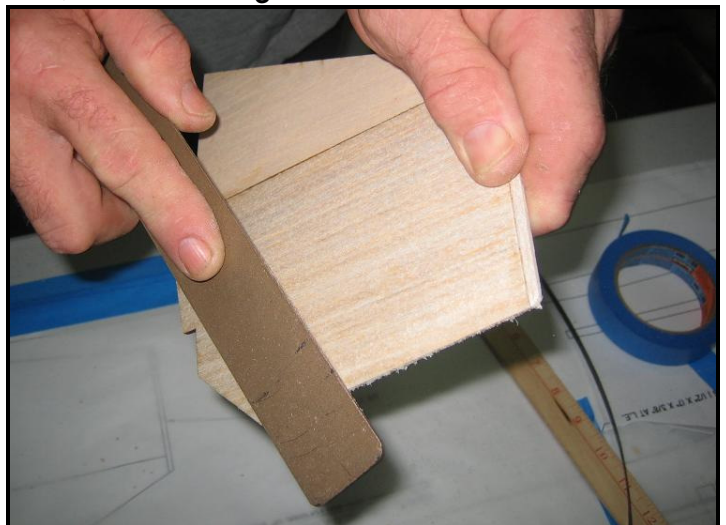

Section 3: Vertical Fin Assembly – Cont.

□ Step 4

In this step you will be cutting and applying carbon fiber strips to add strength to the vertical fins.

Locate the 1/4"x34" carbon fiber strips and cut four of each the following pieces;

- 1/4" x 6"
- 1/4" x 6 1/4"
- 1/4" x 4"

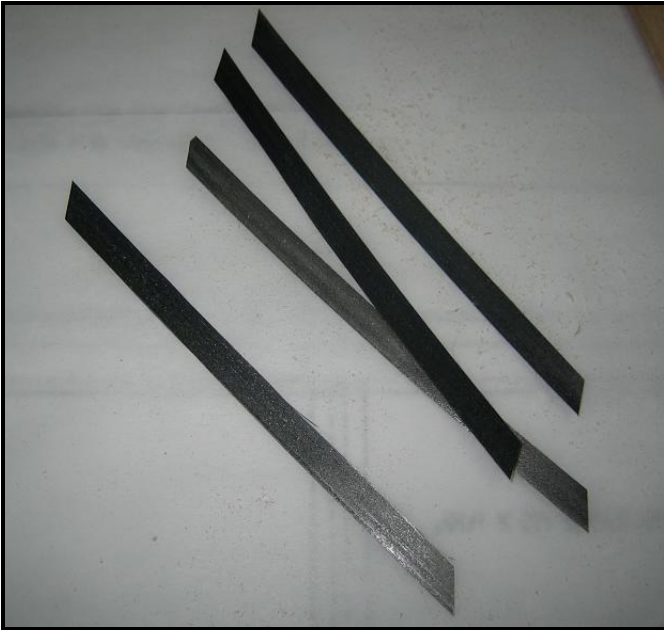

First, apply the 1/4" x 6 1/4" carbon strip along the seam where the front and rear fin halves are joined using thick CA

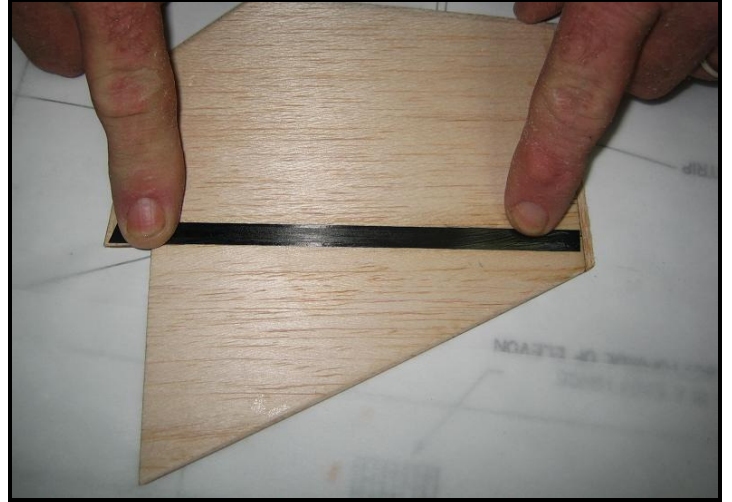

Next, apply the 1/4" x 4" carbon strip across the top of the fins using thick CA.

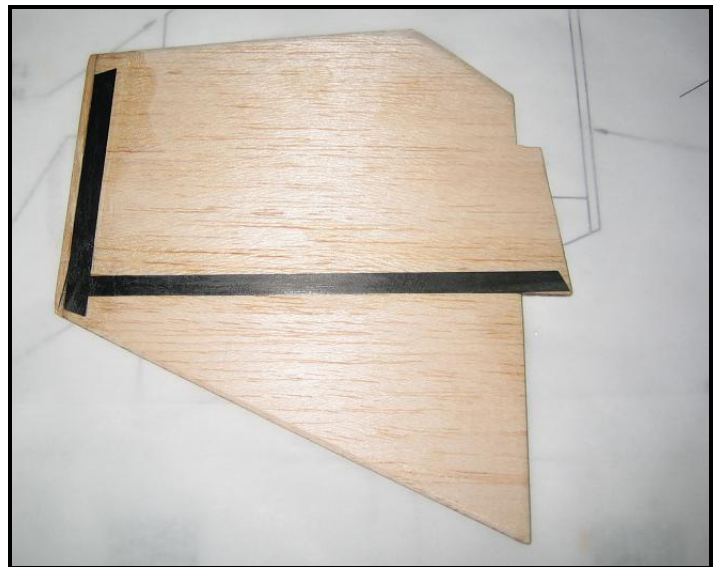

□ Step 5

Step 5 will show you how to apply the carbon strips you just pre-cut to the fins. You will need to repeat this step three more times so that both sides of both fins have carbon applied to them.

Section 3: Vertical Fin Assembly – Cont.

Step 5 - cont.

Install the ¼" x 6" strip across the bottom of the fins above the fin insert tab, again using thick CA.

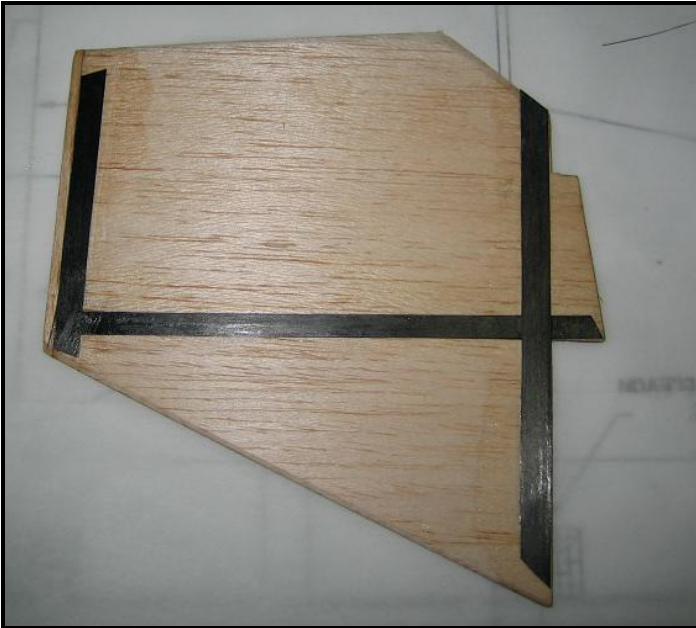

When you are finish applying all three carbon strips, trim any excess carbon flush with the fins. **Note: Repeat step 5 for both sides on both fins.**

Step 6 – Optional Servo Hatch

Due to various servo sizes and servo choices available, we have left it up to the end user to decide whether or not to fabricate a servo hatch cover for the servo/ radio compartment. A servo hatch is not necessary, you can cover the aircraft and add a small piece of covering to cover the servo area, but it does simplify things when access is needed.

We have included a few photos of the hatch we have constructed using left over 1/16" cap strip and cross grain sheeting.



Section 4: Installing the Control Horns and Elevon Linkage

Step 1

Locate the two control horns along with **(8) 4-40 x 1"** cap screws from the parts bag.

Before drilling the holes to mount the control horns, make sure you have properly positioned the control horn so the base of the control horn is flush with the seam, where the triangle stock and elevon stock are joined on top of the control horn pad.

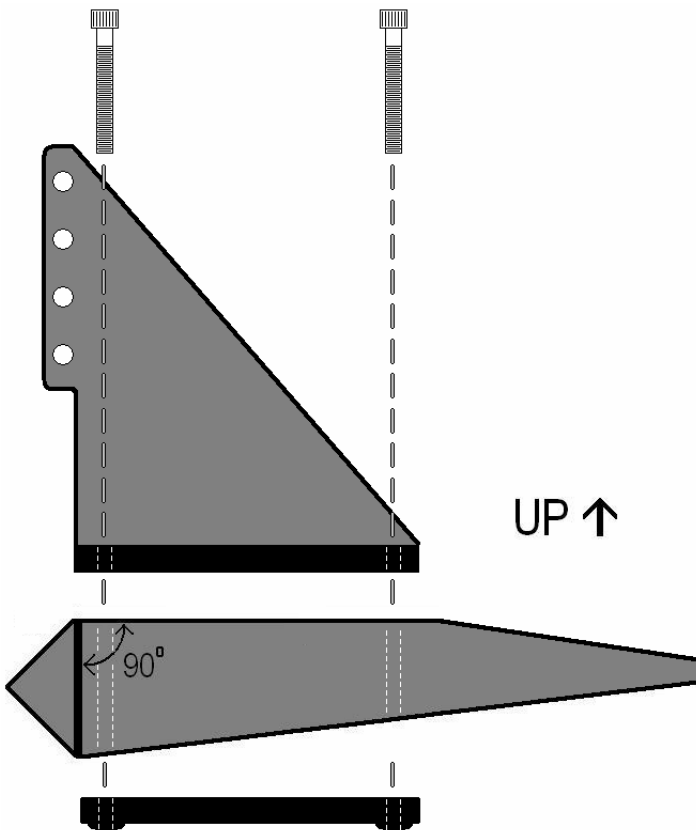

Once properly aligned, mark and drill four holes in the elevons using a 1/8" drill bit. Install the 4-40 x 1" cap screws and **LIGHTLY TIGHTEN AS TO NOT CRUSH THE ELEVONS!!**



Step 2

Next, you will have to determine which hole on the control horn you will be installing the ball link. If you are using high torque servos, we recommend that you use longer servo arms. No matter what length servo arms you decide to use with your servos, you should use a ratio of 1:1.

Section 4: Installing the Control Horns and Elevon Linkage – Cont.

□ Step 2 - cont.

To determine the correct hole to drill, place a servo arm against the control horn and use the closest hole to match the length of the servo arm and control horn with a ratio of 1:1.

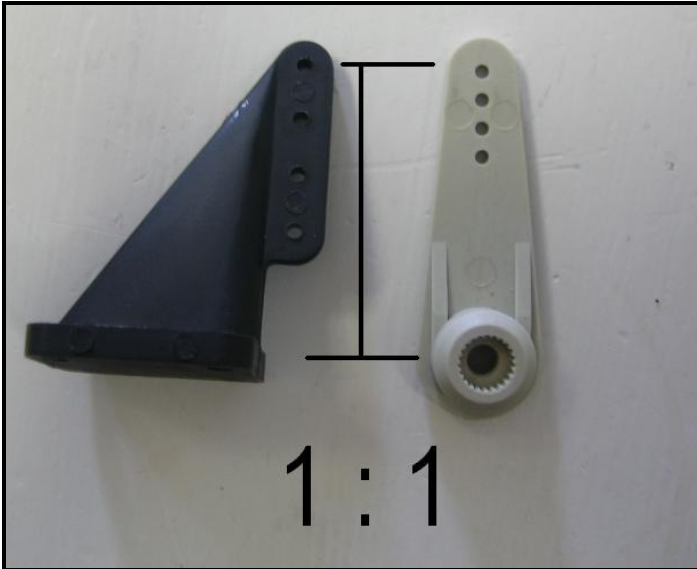

Now that you have determined the proper hole to drill, drill a 3/32" hole in both of the control horns. Use a 7/64" bit to drill the holes in the servo arms.



Next, install the 4/40 ball links as shown below on both control horns.

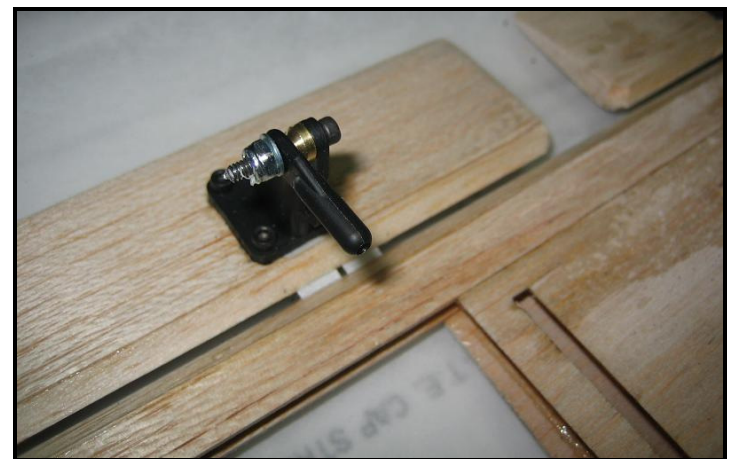
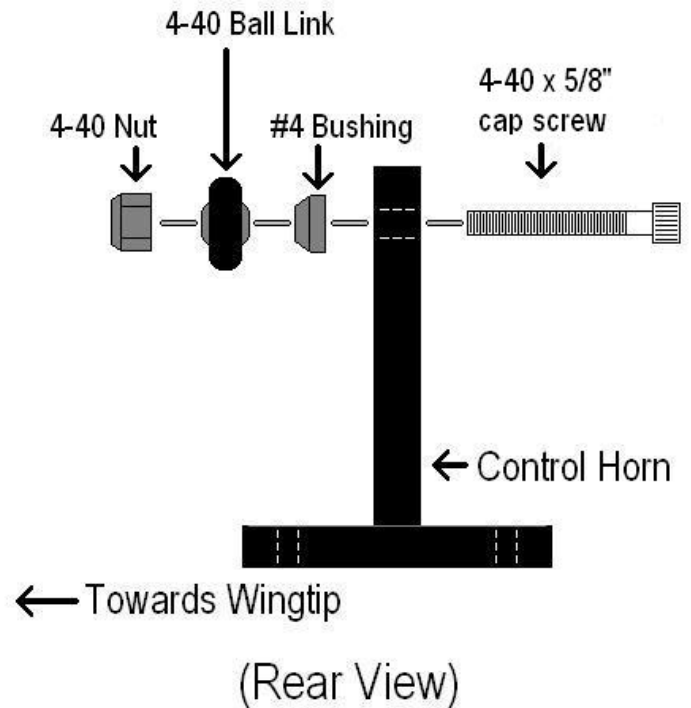

NOTE: Make sure you don't over tighten the ball joint assembly! Check to make sure the ball joint rotates freely and effortlessly.

Section 4: Installing the Control Horns and Elevon Linkage – Cont.

□ Step 3

Locate the two push rods and the two composite pushrod stiffener tubes. Insert one of the pushrods into one of the stiffener tubes, until there is approximately ¼" past the threaded section of the rod left exposed on one end. Next, take a scrap piece of balsa sheeting and create some balsa sawdust with some sand paper or a file. Take the saw dust and pack the stiffener tube with enough sawdust to pack the end.



Once you have the sawdust packed in, wick in some thin CA and allow it to dry. Do this for both ends on both pushrods.



Next, place a drop of thin CA at the tip of the stiffener tube and wrap about 6 wraps of Kevlar thread around the tube.



When you are done wrapping the Kevlar, apply thin CA and allow it to dry.



Section 4: Installing the Control Horns and Elevon Linkage – Cont.

□ Step 4

Screw the pushrods on to the ball links on each elevon about halfway to start.

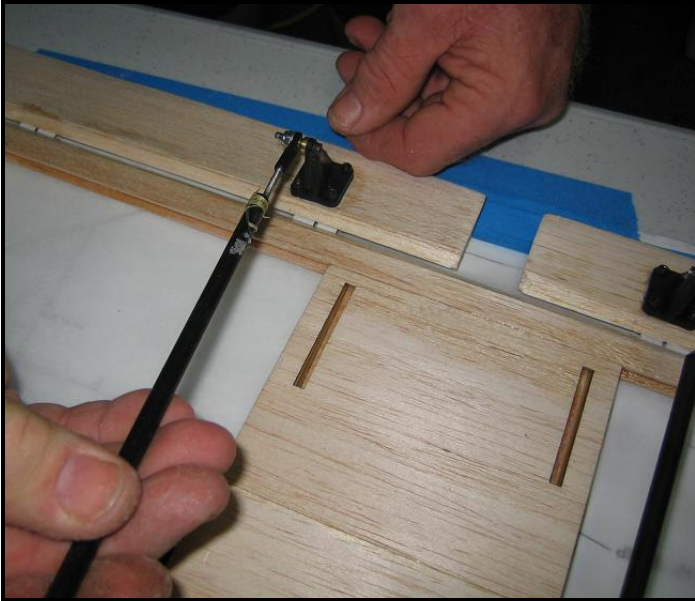

Reinstall your elevon servos and install the control arms to the pushrods, making sure to install the servo arms in the center of your servos.

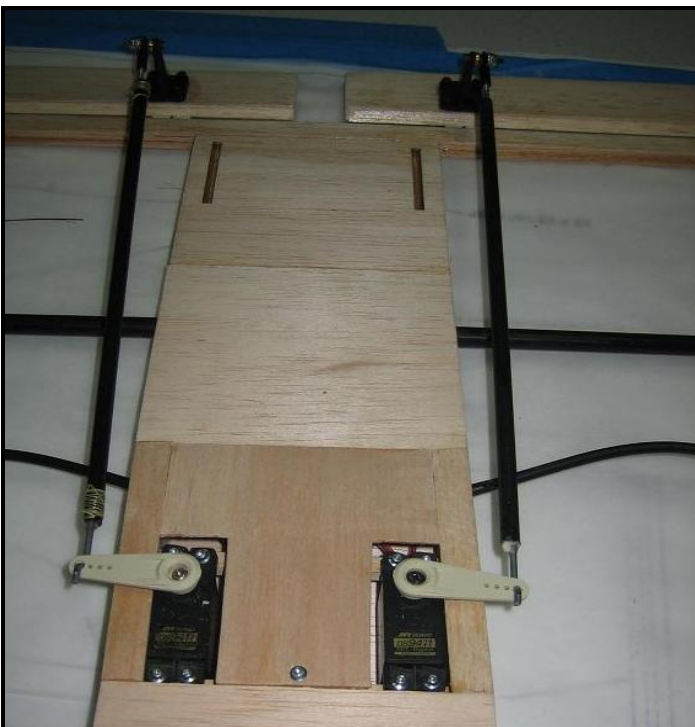

Note: You must power on your radio system in order to properly center your servos at their true center. Make sure your sub-trims are zeroed out as well.

□ Step 5

Fuel Tank Assembly

Assemble the fuel tank stopper and brass tubing as shown below. Care should be taken to not kink the vent tube when bending. Also make sure to leave approximately $\frac{1}{4}$ " of play between the clunk and the back wall of the fuel tank.

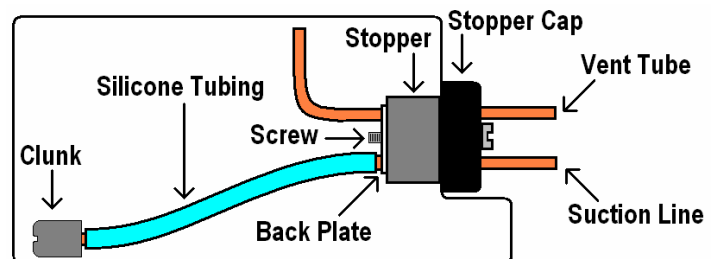

Section 5: Equipment Placement and Pre-Balancing

Step 1

Gather the receiver, receiver battery, power switch harness, fuel tank, throttle servo, vertical fins and engine with prop. Insert the two vertical fins in the rear slots. Place the fuel tank in the fuel tank compartment and install the throttle servo. Center the engine on the motor mount plate so it can be moved forward or aft later.

Do not drill engine mounting holes at this time!

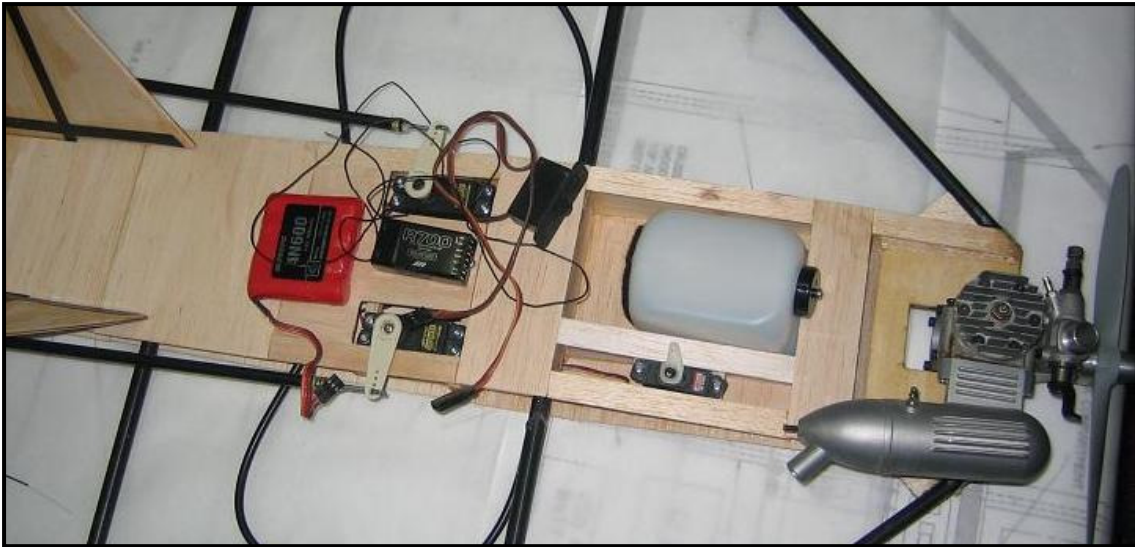

NOTE: Due to many choices in battery size, type, and weight, it will be up to the end user to determine the best location and best method in which to place and mount the battery to the airframe. We have a few suggestions on the plans but they are merely a suggestion.

Step 2

Next, try and arrange your equipment so the aircraft balances perfectly at the high point of the #1 ribs. The motor mount plate should be level with the table as shown below. **NOTE:** once you apply covering the aircraft will be slightly tail heavy in regards to the balance point you have established with the airframe uncovered. Make sure you allow for movement of your battery and engine to establish final balancing in Section 7.

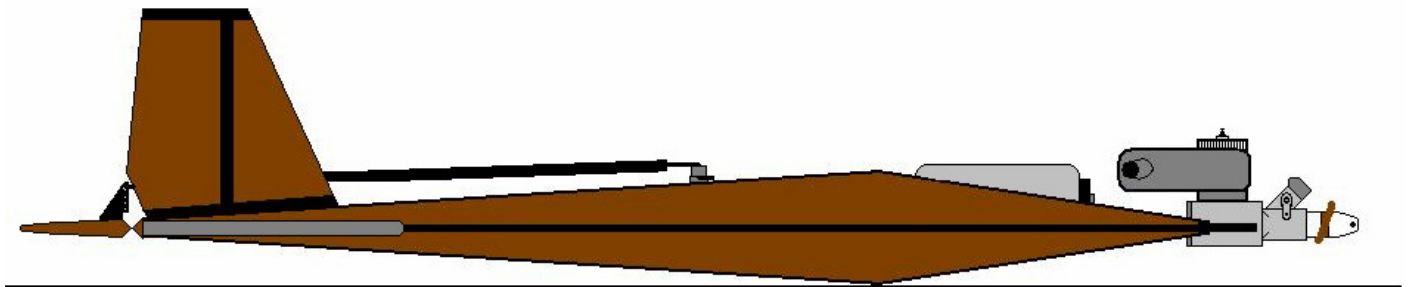

Section 6: Covering the Aircraft.

□ Step 1

Fuel proofing: Apply a layer of Stix-it on the wood portion of the airframe where the covering will contact the wood parts of the aircraft as well as on the leading edge tubes. This will make the covering adhere better and provide fuel proofing to the wood parts of the aircraft.



Stix-It is available from SIG Manufacturing at www.sigmf.com

Apply a moderate coat to the aircraft using a small brush and allow the Stix-It to dry for about 5 minutes or so. Make sure you thoroughly coat the Fuel compartment and motor mount areas. This will help preserve your airframe for many years.



□ Step 2

Now locate the 1" wide roll of Solartex from the parts bag and with a med to hot covering iron, apply a strip across the bottom of the airframe above the forward and rear spars. Remember to remove the clear backing from the Solartex before ironing it down to the airframe.

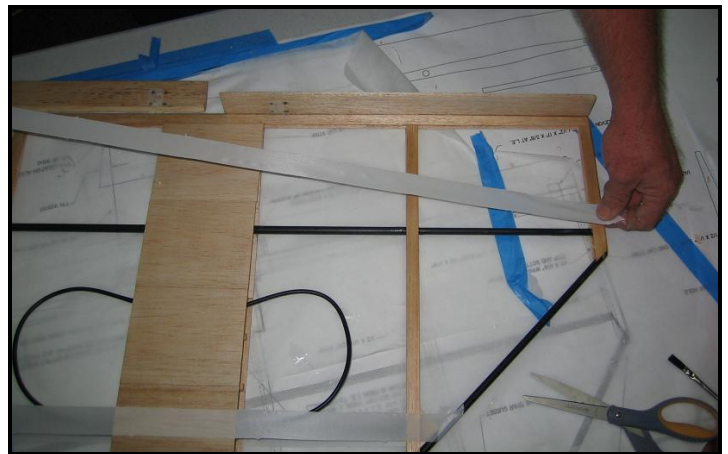

Make sure to wrap around the leading edges, over the forward spar, and around the wingtips on the strip over the rear spar. Pull the strips tight to the other side of the airframe and heat-seal them in place. Next, apply more Stix-It to the already installed Solartex and repeat this step for the strips on the topside of the airframe.

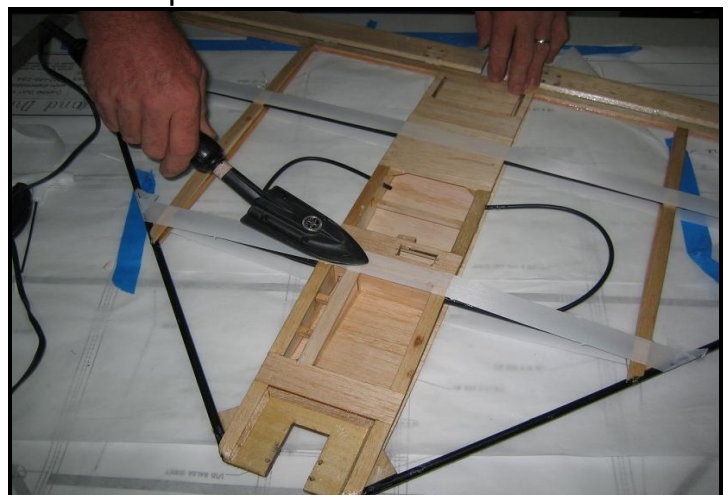

Section 6: Covering the Aircraft - Cont.

□ Step 2 - Cont.

Apply a final coat of Stix-it to the top of the Solartex strips. This important step will allow the covering to have more attachment area as well as provide better adhesion to the Solartex strips.

□ Step 3

The covering procedure is best started by covering the motor mount first. We recommend using Hangar 9 Ultracote or Solartex to cover the Diamond Dust. These coverings have proven to be more resilient and will not shatter as easily with age.

Cover both the top and bottom of the motor mount .

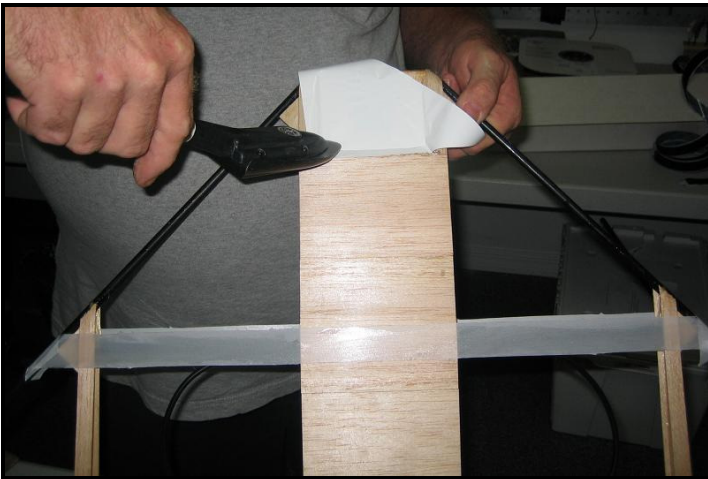

□ Step 4

Follow the same methods as covering most aircraft. Start with the bottom and cover half of the airframe at time, making sure the first half completely covers the center cross grain sheeting and the elevon. Using an iron, tack down the center, then pull it tight and tack it down at the tip. Do the same with the leading and trailing edge. When this is complete, seal the entire perimeter while pulling all the wrinkles out. **DO NOT TIGHTEN COVERING WITH IRON OR HEAT GUN AT THIS TIME!** Iron the covering into the crevice between the elevon and trailing edge and entire elevon, while holding the elevon at full deflection. ***The wing and elevon should be covered using one continuous piece of covering.*** NOTE: Make sure to fully deflect the elevons when ironing the covering in the hinge area.



Section 6: Covering the Aircraft - Cont.

Step 5

Cover the other bottom half in the same manner as shown in step 4. Make sure you overlap the center section by at least ½”.



Step 6

Turn the airframe over and install a piece of covering that will cover the entire center section, including the elevons all the way out to the #2 ribs.

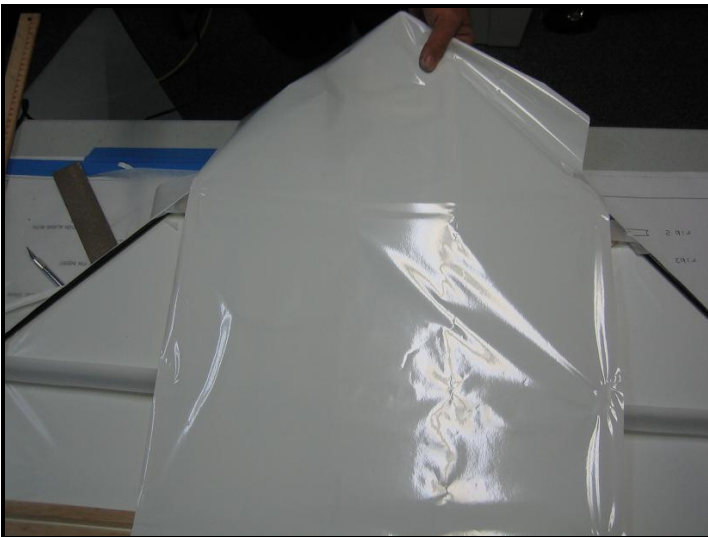

Step 7

In this step you may choose to cover the remaining tip sections of the wings with a different color. This will help with orientation when the Diamond Dust is in the air. Make sure you overlap the first layer of covering over the #2 ribs.

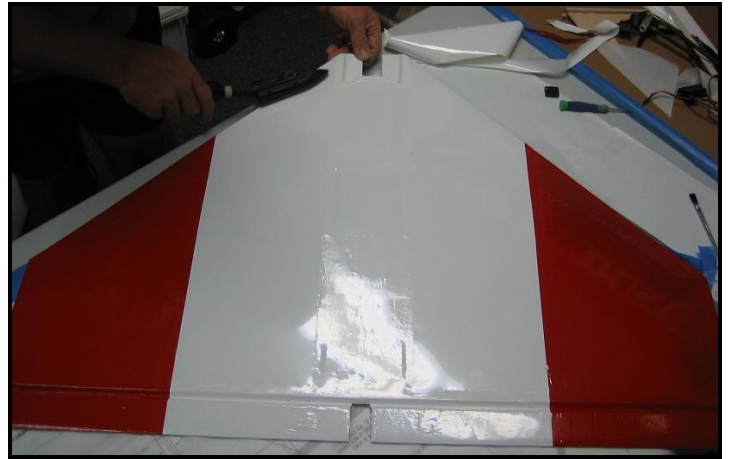

Once you have all of the covering installed, make sure to tack down the covering and make a final pass along the leading edges and over the center sheeting and motor mount area.



Section 6: Covering the Aircraft - Cont.

Step 8

Look at the aircraft from a frontal view and determine if both wingtips are even with each other. If not keep this in mind while tightening the covering so you can make any minor corrections. If this aircraft does not trim out the same at high and low speeds then you probably have some difference in wingtip incidence and this can still be corrected by re-tightening the covering.

Tighten the covering lightly on each side before tightening completely.

Step 9

Once the covering is tightened, cut the covering over the radio and fuel tank compartments. You might want to leave some extra around the compartments so you can roll the covering into the openings with your iron.



Step 7

Cover both vertical fins with covering. Make sure to not cover the bottom of the fin or the fin insert tab. Make sure when you cover the fins that they are on a flat surface to keep them straight.



Next Carefully cut out the fin insert holes that are located on the rear top sheeting of the airframe.

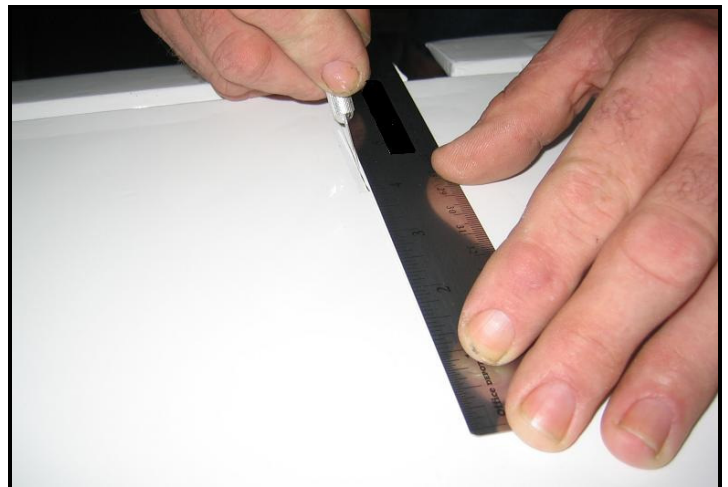

Section 6: Covering the Aircraft - Cont.

□ Step 8

Insert a vertical fin in the fin insert slot and mark with a pencil where the fin makes contact with the cross grain sheeting. Then, cut away the covering to expose the balsa sheeting underneath the vertical fin.

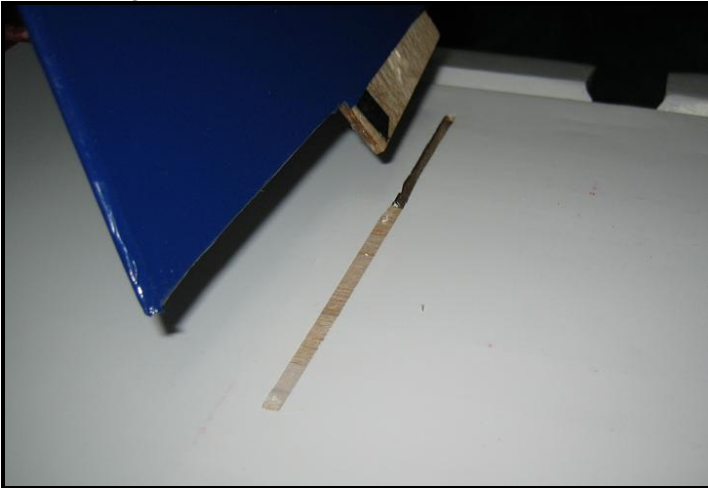

Repeat this step for both slots.

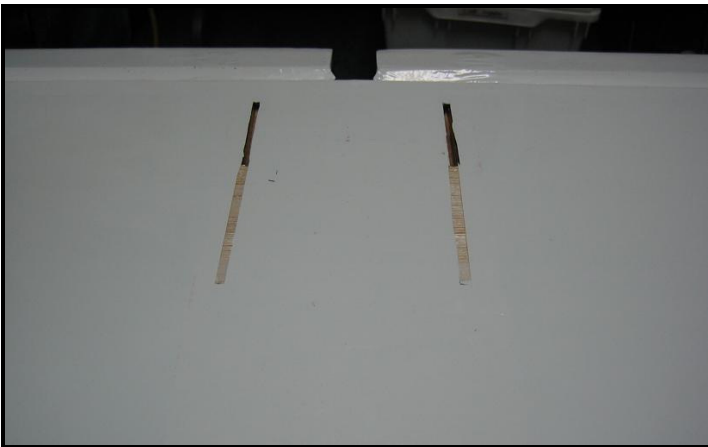

□ Step 7

When installing the fins, use the fin gage. Use thick CA on the fin insert where it makes contact with the offset spacer and the bottom cross grain sheeting.

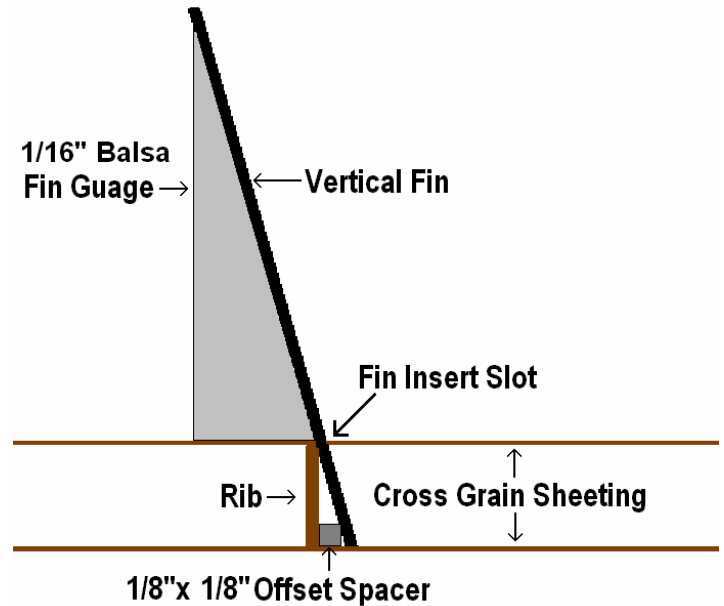

After installing both fins, lay a small fillet of thick CA around the base of both fins.



Section 7: Fuel Tank Installation

Step 1

Locate the Velcro strap from the kit and place it in the middle of the fuel tank compartment and glue with thin CA. **Make sure to glue the "loop" side down.** The eye side of the strap should stick out approximately 2 to 3 inches.



Step 2

Next, place a small amount of foam rubber or padding where the fuel tank will go.



Step 3

Install the fuel tank and latch the Velcro strap around the fuel tank.

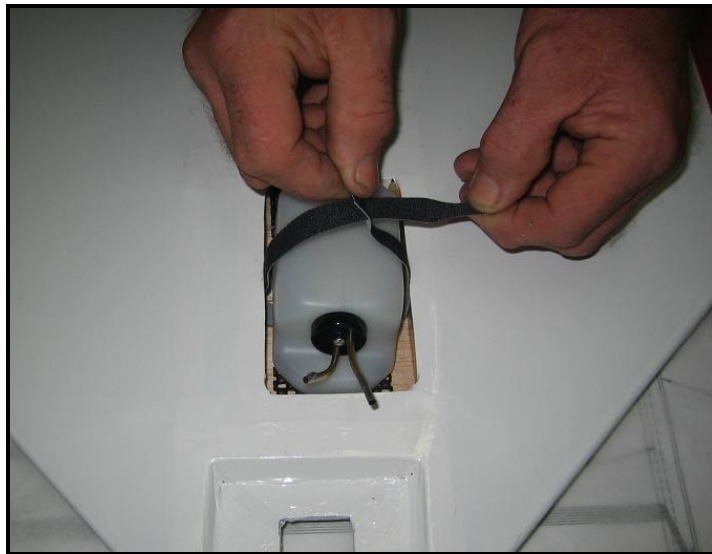

Step 4

Attach your fuel lines from the tank to carburetor. Make sure you connect the pick up line

Section 8: Final Equipment Installation

□ Step 1

Make sure your radio equipment is operating correctly and your servo arms are centered. Also be sure to zero out your trims and servo trims on your transmitter **BEFORE** installing your servo arms at center! This also includes checking servos for proper direction before attempting to cover the air frame as mentioned earlier.

Note: You may need to alter your radios mixing in order to achieve proper orientation. Some radios offer a delta wing configuration

Tip: Because of the amount of force placed on the Diamond Dust's control surfaces, plastic geared servos can fail prematurely. Therefore we strongly suggest the use of metal geared servos like the JR DS9411, DS8611A or Hitec HS-5625MG.

□ Step 2

Ensure you have proper servo direction before you install servos.

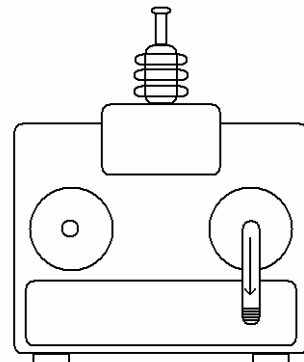
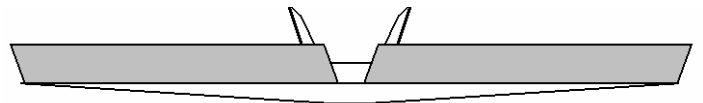

Elevator UP

Both servos pull forward

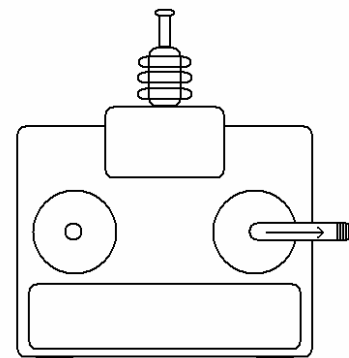
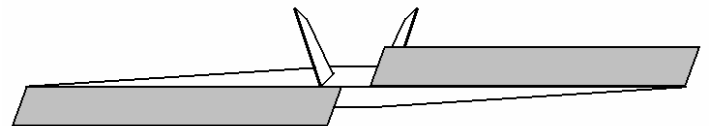

Aileron Right

Right Servo pulls forward
Left servo pushes back

Section 8: Final Equipment Installation – Cont.

Step 3

After you have established proper servo movement and centering, Install your elevon servos in the servo/ radio compartment and attach the control linkage to the elevons.

NOTE: Complete steps 4 through 7 only if you have a receiver that has a long wire antenna. If you are using a spread spectrum receiver, then install your receiver as per the manufacturers instructions and then please proceed to Step 8.

Step 4

Locate the small yellow antenna pull tube and cut a small slit halfway through the tube about 1/2" back from one end. Leave enough tubing attached so you can hinge the 1/2" piece of tubing back

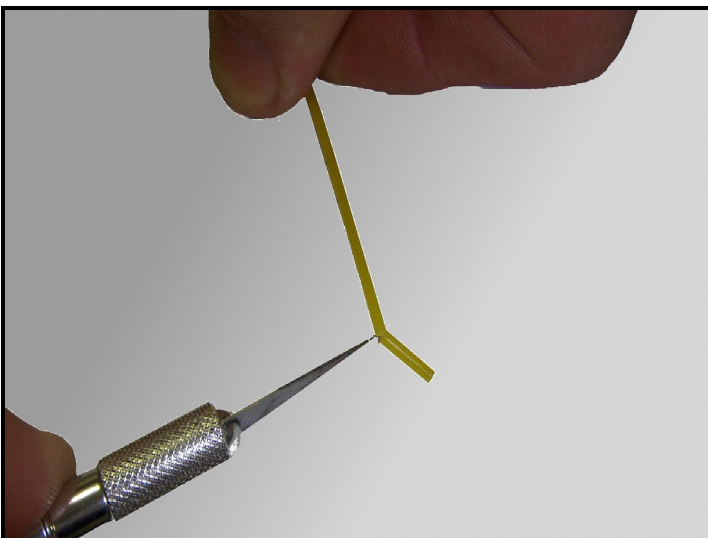

Step 5

Pull the short semi-cut section back to open the tube so you can insert the end of the antenna in the open end on the short side of the cut.

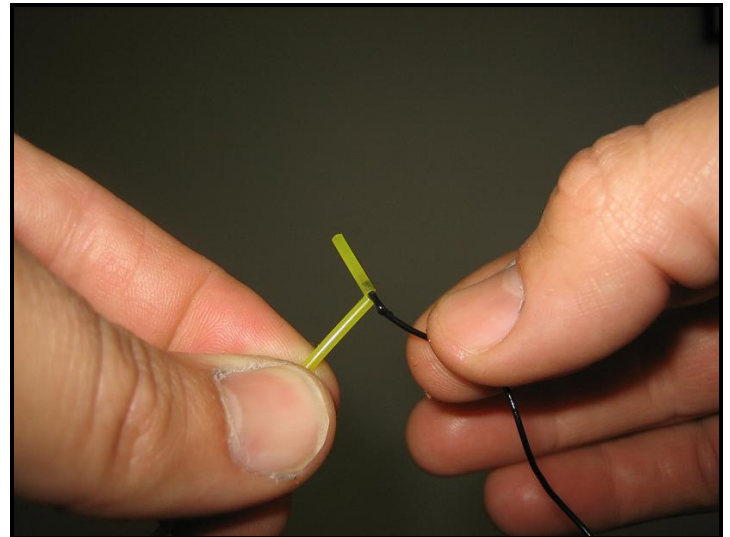

Step 6

Insert the opposite end of antenna pull tube into one side of the antenna tube and feed it through until it comes out the other side.

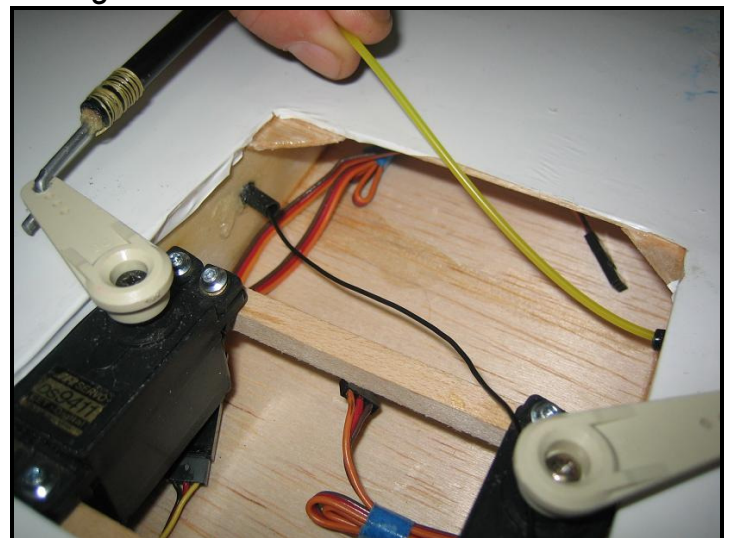

Section 8: Final Equipment Installation – Cont.

Step 7

Continue pulling the pull tube until the antenna exits the other side of the guide tubing..

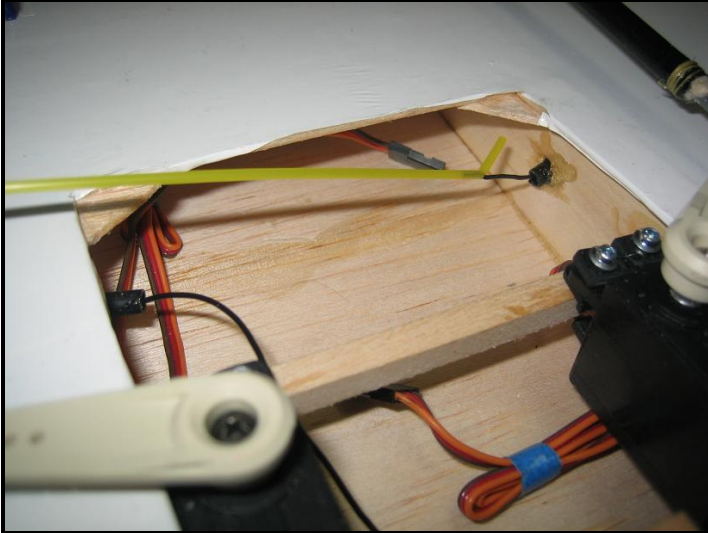

Step 8

Install your receiver in the location you established when balancing the aircraft in Section 5.

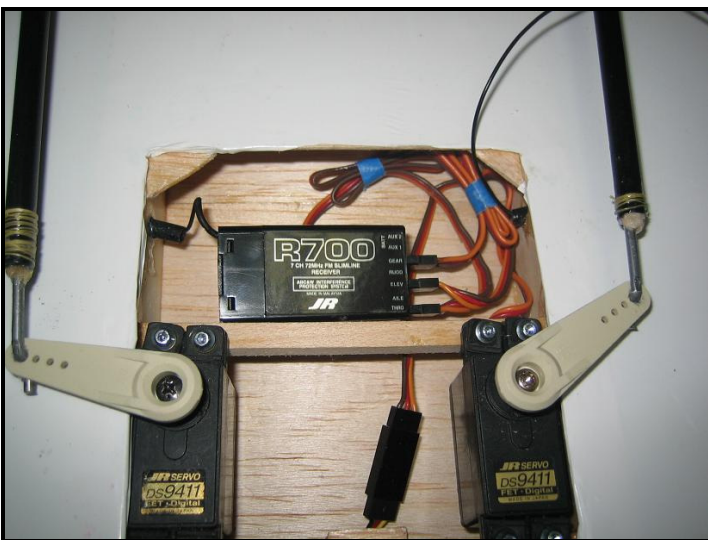

Step 9

NOTE: Due to battery size, type, and weight, It will be up to the end user to determine the location and manner in which the battery will be attached to the airframe. We have a few suggestions on the plans but they are merely Suggestions.

Install the battery in the location you determined in Section 5. You may have to slide the tank forward or backwards in order to insert you battery at the desired location.

Step 10

Locate the 2-56 pushrod and nylon clevis. Thread the nylon clevis onto the 2-56 pushrod about half way on to the threads. Attach the clevis to your engine and determine the correct length needed and create a z bend at the servo arm.

NOTE: make sure your servo arm is in the proper throttle position in respect to your carburetor position.

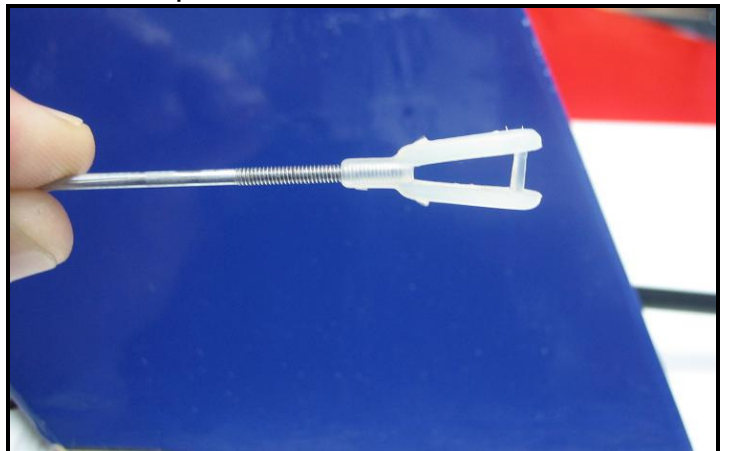

Section 9: Final Inspection/Control Throws

Step 1 Control Throws:

Give the aircraft a complete check over and make sure the airframe and all control surfaces are straight.

Also make sure that with up and down elevator your elevons stay equal through their range of motion.

Start out with 1" up & 1" down of travel with both elevator & ailerons. Later, you can increase the travel on the elevator until it starts to stall for high rate. You can also adjust the aileron throws, until they reach full deflection.

We recommend that you use 100% expo on your ailerons and 25% on your elevator for the test flight.

	Low Rate	High Rate
Elevator	3/8" up 3/8" down	3/4" up 3/4" down
Aileron	3/8" up 3/8" down	Max Throw up Max Throw down

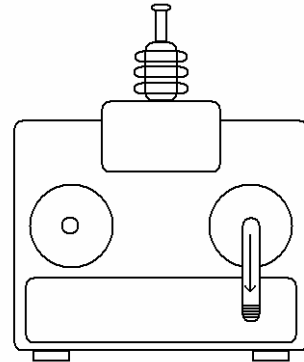
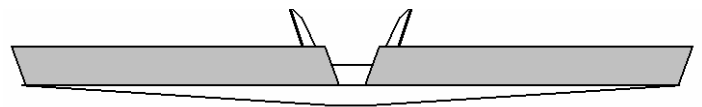

Elevator UP

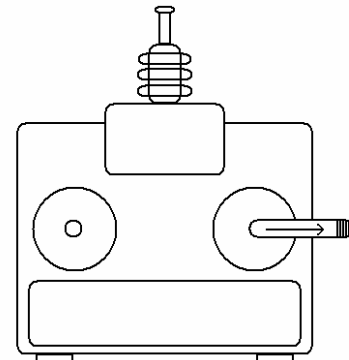
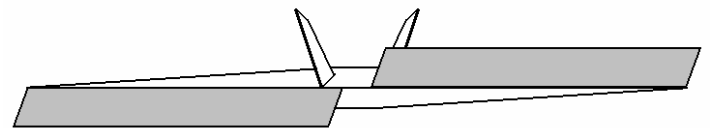

Aileron Right

Make sure that you have the proper direction in relation to your radio stick moves.

Section 10: Balancing The Diamond Dust

Step 1

Recommended CG:

An important part of preparing the aircraft for flight is properly balancing the model.

The recommended Center of Gravity (CG) for the Diamond Dust is at the high point of the main ribs to ½" in front of the high point.

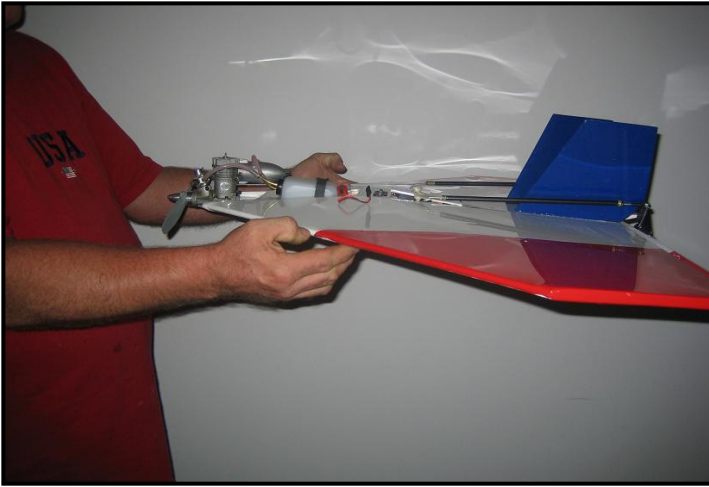

To properly check the balance the aircraft, suspend the plane with your fingers on the leading edge of the wing where the forward main spar intersects the leading edge.

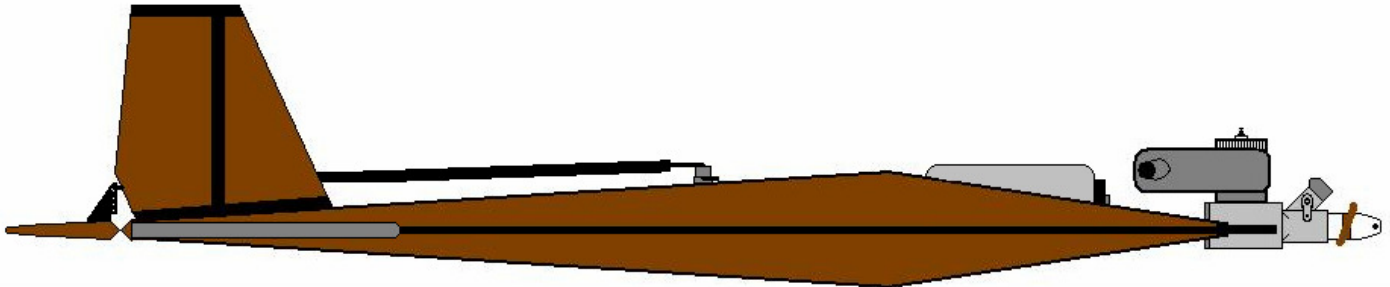

If necessary, move the battery pack, receiver, or add weight to either the nose or the tail until the correct balance is achieved. Stick-on weights are available at your local hobby shop and work well for this purpose.

Note: It is always better to move equipment around on the aircraft instead of adding weight in order to achieve proper balance.

If you have assembled this aircraft with the components we have suggested, your balance should be very close.

Remember you can still move your engine forward or backwards on the motor mount plate.

Section 11: Pre-Flight & At the Flying Field

Step 1 Preflight check:

Charge both the transmitter and main battery pack for your airplane. Use the recommended charger supplied with your particular radio system, following the instructions provided with the radio. In most cases the radio should be charged the night before going out flying.

Check the radio installation and make sure all the control surfaces are moving correctly (i.e. the correct direction and with the recommended throws).

Check all the control horns, servo arms and clevises to make sure they are secure and in good condition. Replace any items that would be considered questionable. Failure of any of these components in flight would mean the loss of your aircraft.

Step 2 Range testing the radio:

Before each flying session, range-check your radio. This is accomplished by turning on your transmitter with the antenna collapsed. Turn on the radio in your airplane. With your airplane on the ground, you should be able to walk 30 paces or 75ft away from your airplane and still have complete control of all functions.

If not, do not attempt to fly! Have your radio equipment checked out by the manufacturer.

Step 3

Initial Instructions for Takeoff

Have an assistant hold the aircraft from behind with one hand over the leading edge of each wing tip. When engine is running $\frac{1}{2}$ to $\frac{3}{4}$ power, have your assistant release the aircraft in a level or slightly nose high altitude. If you are using a .25 engine or larger just release, DO NOT TOSS, the aircraft. It will have ample power and will remain in better control if you simply release it. If using, smaller than a .25 then a gentle toss may be necessary. Be careful not to toss towards the ground or too nose high. If the engine quits upon release it may have a bad glow plug or it just may be accelerating faster than the fuel can be supplied. Try a new plug and or launching at lower throttle setting.

Section 11: Pre-Flight & At the Flying Field – Cont.

Step 4 LANDING:

NOTE: Landings are usually done on soft grass. Dirt or sand is not recommended.

- (A) Get into a high approach and shut off engine.
- (B) While at high altitude slow the aircraft down by bringing it to nose high attitude and get the feel of its low speed glide characteristics.. Be careful not to stall the aircraft.
- (C) Once you have done this gently push the nose down to build up flying speed and bring it in for the final approach being careful not to build up too much speed.
- (D) Make a final slow down by gently flaring the aircraft.
- (E) Hold your flare and the aircraft will settle in very controlled on the belly of aircraft.

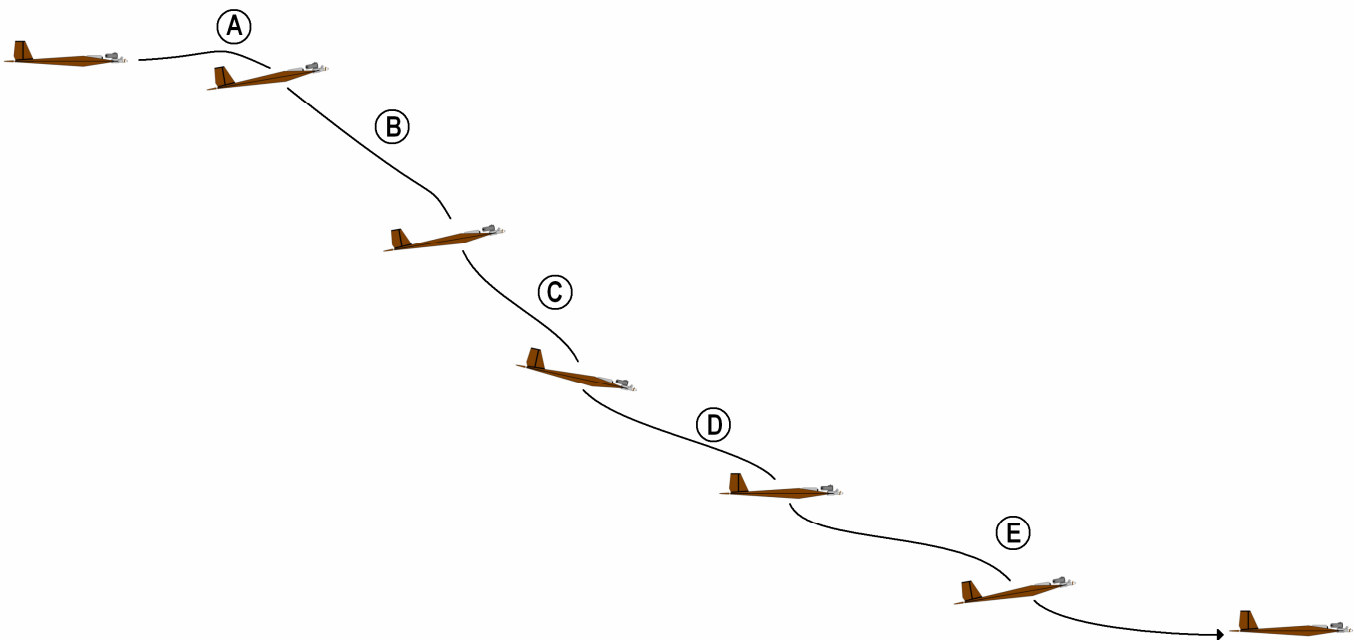



www.diamonddustrc.com



© 2007 Tetracam, Inc
21601 Devonshire Street
Suite 310
Chatsworth, California 91311
www.tetracam.com
Sales - (818) 718 -2119
Tech Support – (352) 871-7301